

SONY[®]

User guide

Xperia™ Z2 Tablet
SGP561

Contents

Getting started	5
About this User guide.....	5
Tablet Features.....	5
Setting Up Your Tablet.....	6
Starting your device for the first time.....	8
Why do I need a Google™ account?.....	8
Charging Your Tablet.....	8
Learning the basics	10
Using the touchscreen.....	10
Locking and unlocking the screen.....	11
Home screen.....	12
Application screen.....	13
Navigating applications.....	14
Small apps.....	14
Widgets.....	15
Shortcuts and folders.....	16
Background and themes.....	17
Status and notifications.....	17
Icons in the status bar.....	18
Application overview.....	20
Downloading applications	21
Downloading applications from Google Play™.....	21
Downloading applications from other sources.....	21
Internet and networks	22
Browsing the web.....	22
Wi-Fi®.....	22
Sharing your mobile data connection.....	23
Controlling data usage.....	24
Virtual private networks (VPNs).....	25
Synchronizing data on your device	27
Synchronizing with online accounts.....	27
Synchronizing with Microsoft® Exchange ActiveSync®.....	27
Basic settings	29
Accessing settings.....	29
Sound volume.....	29
SIM card protection.....	30
Screen settings.....	30
Screen lock.....	31
Language settings.....	32

Date and time.....	32
Enhancing the sound output.....	33
Noise cancellation.....	33
Typing text.....	34
On-screen keyboard.....	34
Entering text using voice input.....	35
Editing text.....	35
Personalizing the Xperia keyboard.....	36
Contacts.....	37
Transferring contacts.....	37
Searching and viewing contacts.....	37
Adding and editing contacts.....	38
Favorites and groups.....	39
Sending contact information.....	39
Avoiding duplicate entries in the Contacts application.....	39
Backing up contacts.....	40
Email.....	41
Setting up email.....	41
Sending and receiving email messages.....	41
Email preview pane.....	42
Organizing your email messages.....	43
Email account settings.....	44
Gmail™.....	44
Music.....	45
Transferring music to your device.....	45
Listening to music.....	45
“WALKMAN” homescreen menu.....	46
Playlists.....	47
Sharing music.....	48
Enhancing the sound.....	48
Visualizer	49
Music Unlimited online service.....	49
Camera.....	50
Taking photos and recording videos.....	50
Face detection.....	51
Using Smile Shutter™ to capture smiling faces.....	51
Adding the geographical position to your photos.....	52
General camera settings.....	52
Still camera settings.....	54
Video camera settings.....	57
Photos and videos in Album.....	60
Viewing photos and videos.....	60

Sharing and managing photos and videos.....	61
Editing photos with the Photo editor application.....	62
Album homescreen menu.....	63
Viewing your photos on a map.....	64
Videos.....	66
Watching videos in the Movies application.....	66
Transferring video content to your device.....	67
Managing video content.....	67
Video Unlimited service.....	67
Connectivity.....	69
Mirroring the screen of your device on a TV using a cable.....	69
Mirroring the screen of another Xperia™ device wirelessly on your device	69
Mirroring the screen of your device wirelessly on a TV.....	69
Sharing content with DLNA Certified™ devices.....	70
Playing games on a TV using a DUALSHOCK™3 wireless controller.....	72
NFC.....	73
Bluetooth® wireless technology.....	75
One-touch setup.....	77
Using your device as a fitness hub with ANT+™.....	78
Travel and maps.....	79
Using location services.....	79
Google Maps™ and navigation.....	79
Using your device with a car infotainment system.....	81
Airplane mode.....	81
Calendar and alarm clock.....	82
Calendar.....	82
Alarm and clock.....	83
Support and maintenance.....	85
Help for your device.....	85
Media Formats.....	85
Finding a lost device	87
IMEI number.....	87
Battery and power management.....	87
Memory and storage.....	89
Managing files using a computer.....	90
Restarting and resetting.....	91
Using your device in wet and dusty conditions.....	92
Recycling your device.....	93
Limitations to services and features.....	94
Legal information.....	94

Getting started

About this User guide

This is the **Xperia™ Z2 Tablet** User guide for the **Android™ 4.4** software version. If you're not sure which software version your device is running, you can check it via the Settings menu.

To check the current software version of your device

- 1 From your Home screen, tap ☰.
- 2 Find and tap **Settings** > **About tablet** > **Android version**.

Tablet Features

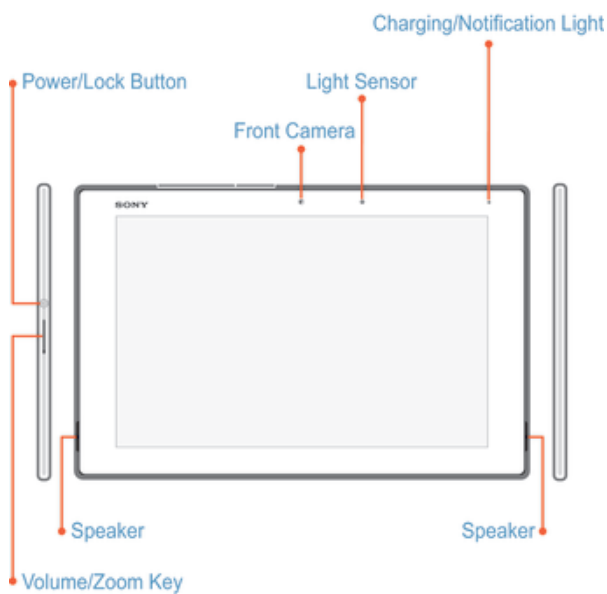

Not all features, apps or services may be available with your plan, device operating system and software version. Please contact Verizon Wireless for more information.

- ! Devices and software are constantly evolving—the screen images and icons you see here are for reference only.

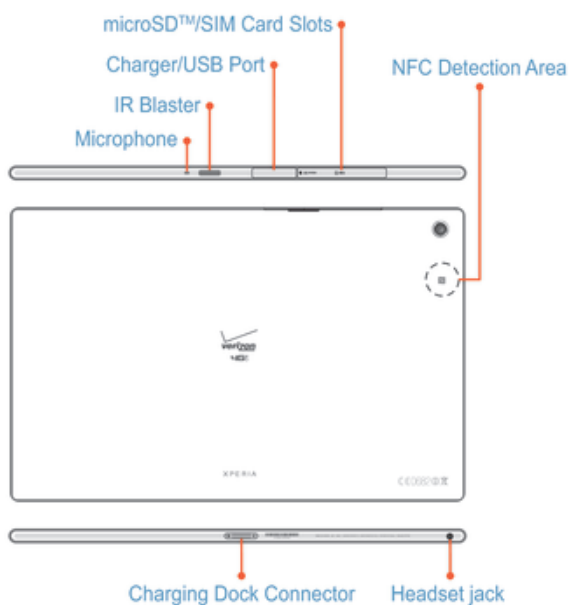

Setting Up Your Tablet

A protective plastic sheet is attached to the screen. You should peel off this sheet before using the touchscreen. Otherwise, the touchscreen might not function properly.

Inserting the SIM Card

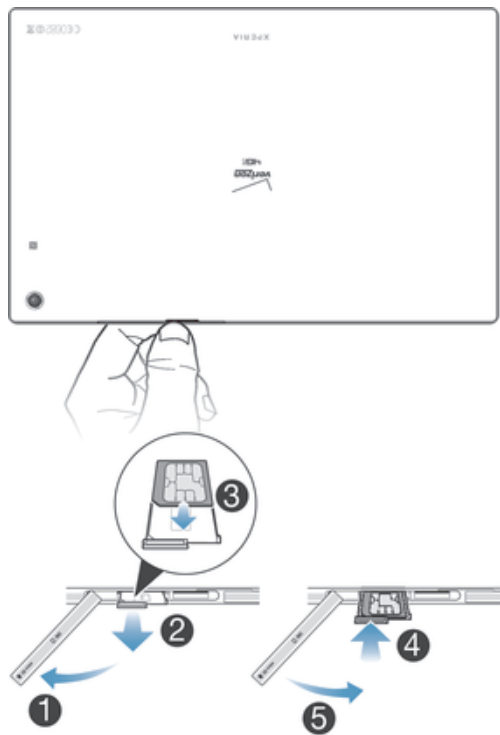

- 1 Open the SIM card slot cover.
 - 2 Using a fingernail, pull out the SIM card holder.
 - 3 Carefully insert the 4G LTE SIM card into the SIM card holder with the Verizon logo facing up.
 - 4 Push the SIM card holder back into place.
 - 5 Close the SIM card slot cover.
- ! Inserting the SIM card into the device without the SIM card holder could damage your SIM card or your device, and Sony Mobile does not warrant and will not be responsible for any damage caused by such action.
 - ! To ensure the water resistance of your device, the cover for the SIM card slot must be firmly closed.

Removing the SIM Card

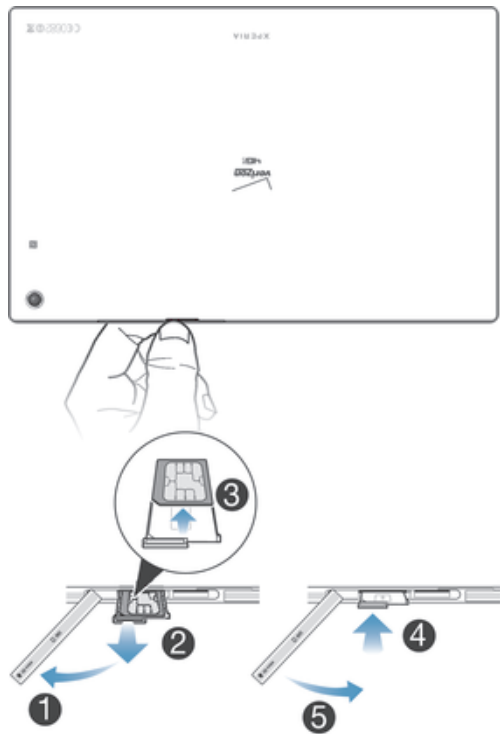

- 1 Open the SIM card slot cover.
- 2 Using a fingernail, pull out the SIM card holder.
- 3 Remove the SIM card.
- 4 Push the SIM card holder back into place.
- 5 Close the SIM card slot cover.

! To ensure the water resistance of your device, the cover for the SIM card slot must be firmly closed.

Inserting the microSD Card

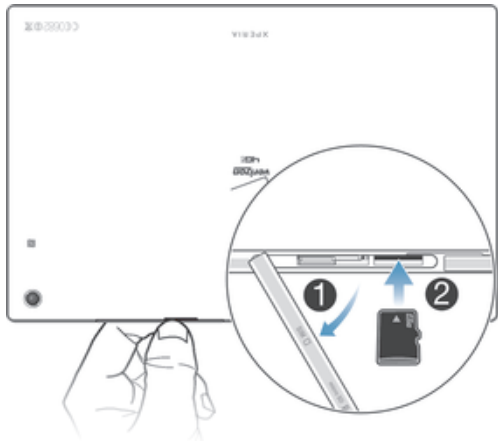

- 1 Open the microSD card slot cover.
- 2 Carefully slide the microSD card into the microSD slot with the gold contacts facing down
- 3 Close the microSD slot cover.

💡 To remove the microSD card, carefully push the card inward to release it from the slot.

! To ensure the water resistance of your device, the cover for the microSD card slot must be firmly closed.

Starting your device for the first time

The first time you start your device, a Setup Wizard opens to help you configure basic settings, sign in to some accounts, and personalize your device. For example, if you have a Sony Entertainment Network account, you can sign in to it here and get set up straight away.

- 💡 You can also access the Setup Wizard later from the application menu to know more about your tablet.

Turning Your Tablet On/Off

It's important to fully charge the battery before turning on your tablet.



To turn on your tablet

- Press and hold the **Power/Lock** button on the left side of your tablet.

To turn off your tablet

- 1 Press and hold the **Power/Lock** button until the Device options screen appears.
- 2 Tap **Power off** > **OK**.

Why do I need a Google™ account?

Your Xperia™ device from Sony runs on the Android™ platform developed by Google™. A range of Google™ applications and services are available on your device when you purchase it, for example, Gmail™, Google Maps™, YouTube™, and Google Play™—the online store for downloading Android™ applications. To get the most out of these services, you need a Google™ account. For example, a Google™ account is mandatory if you want to:

- Download and install applications from Google Play™.
- Synchronize email, contacts, and the calendar.
- Chat with friends using the Hangouts™ application.
- Synchronize your browsing history and bookmarks.

For more information about Android™ and Google™, go to www.sonymobile.com/support.

To set up a Google™ account on your device

- 1 From your Home screen, tap ☰.
- 2 Find and tap **Settings** > **Add account** > **Google**.
- 3 Follow the registration wizard to create a Google™ account, or sign in if you already have an account.

- 💡 You can also sign in to or create a Google™ account from the setup wizard the first time you start your device. Or you can go online and create an account at www.google.com/accounts.

Charging Your Tablet

Your device has an embedded, rechargeable battery that should be replaced only by Sony or an authorized Sony repair center. You should never try to open or take apart this device yourself. Opening the device can cause damage that will void your warranty.

The battery is partly charged when you buy the device. You can still use your device while it is charging. Read more about the battery and how to improve the performance in *Battery and power management* on page 87.

To charge your device

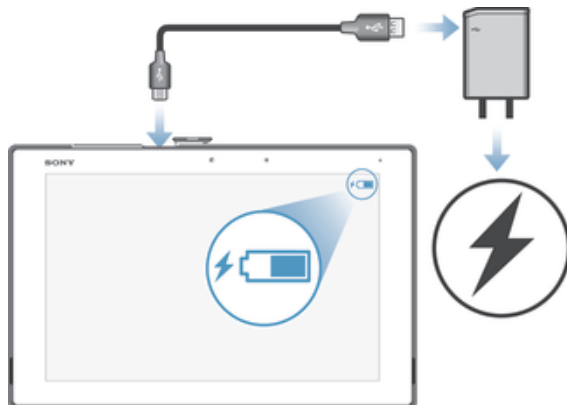

- 1 Plug the charger into a power outlet.
 - 2 Plug one end of the USB cable into the charger (or into the USB port of a computer).
 - 3 Plug the other end of the cable into the micro USB port on your device, with the USB symbol facing up. The notification light illuminates when charging begins.
 - 4 When the device is fully charged, disconnect the cable from your device by pulling it straight outward. Make sure not to bend the connector.
- 💡 If the battery is completely discharged, it may take a few minutes before the notification light illuminates and the charging icon  appears.

Battery notification light status

Green	The battery charge level is greater than 90%
Flashing red	The battery is charging and the battery charge level is less than 15%
Orange	The battery is charging and the battery charge level is less than 90%

Learning the basics

Using the touchscreen

Tapping



- Open or select an item.
- Mark or unmark a checkbox or option.
- Enter text using the on-screen keyboard.

Touching and holding



- Move an item.
- Activate an item-specific menu.
- Activate selection mode, for example, to select several items from a list.

Pinching and spreading



- Zoom in or out on a web page, a photo, or a map.

Swiping

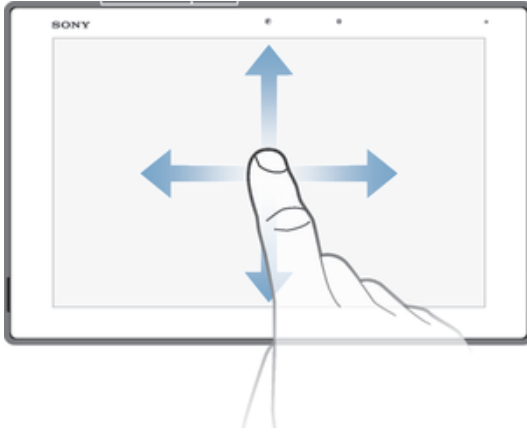

- Scroll up or down a list.
- Scroll left or right, for example, between Home screen panes.

Flicking

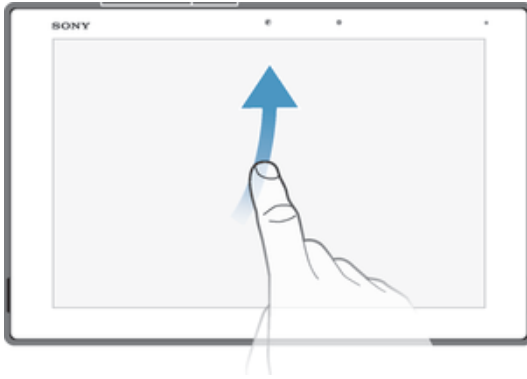

- Scroll quickly, for example, in a list or on a web page. You can stop the scrolling movement by tapping the screen.

Locking and unlocking the screen

When your device is on and left idle for a set period of time, the screen darkens to save battery power and locks automatically. This lock prevents unwanted actions on the touchscreen when you are not using it. When you buy your device, a basic screen swipe lock is already set. This means that you have to swipe in any direction from the right side of the screen to unlock it. You can change the security settings later and add other kinds of locks. See *Screen lock* on page 31.

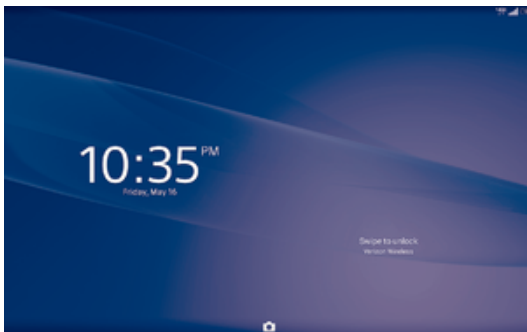

To activate the screen

- Briefly press the power key .

To unlock the screen

- Place a finger on the right side of the screen and swipe in any direction.

To lock the screen

- When the screen is active, briefly press the power key .

Home screen

The Home screen is the starting point for using your device. It's similar to the desktop on a computer screen. Your Home screen can have up to seven panes, which extend beyond the regular screen display width. The number of Home screen panes is represented by a series of dots at the top of the Home screen. The highlighted dot shows the pane that you are currently in.



To go to the Home screen

- Press .

To browse the Home screen



Home screen panes

You can add new panes to your Home screen (up to a maximum of seven panes) and delete panes. You can also set the pane that you want to use as the main Home screen pane.



To set a pane as the main Home screen pane

- 1 Touch and hold an empty area on your Home screen until the device vibrates.
- 2 Flick left or right to browse to the pane that you want to set as your main Home screen pane, then tap  at the top corner of the pane.

To add a pane to your Home screen

- 1 Touch and hold an empty area on your Home screen until the device vibrates.
- 2 Flick left or right to browse the panes, then tap .

To delete a pane from your Home screen

- 1 Touch and hold an empty area on your Home screen until the device vibrates.
- 2 Flick left or right to browse to the pane that you want to delete, then tap .

Application screen

The Application screen, which you open from the Homescreen, contains the applications that come pre-installed on your device as well as applications that you download.



To view all applications on the Application screen

- 1 From your Home screen, tap .
- 2 Flick left or right on the Application screen.

To open an application from the Application screen

- Flick left or right to find the application, then tap the application.

To open the Application screen menu

- When the Application screen is open, drag the left edge of the screen to the right.

To move an application on the Application screen

- 1 To open the Application screen menu, drag the left edge of the Application screen to the right.
- 2 Make sure **Own order** is selected under **SHOW APPS**.
- 3 Touch and hold the application until it magnifies and the device vibrates, then drag it to the new location.

To add an application shortcut to the Home screen

- 1 From the Application screen, touch and hold an application icon until the screen vibrates, then drag the icon to the top of the screen. The Home screen opens.
- 2 Drag the icon to the desired location on the Home screen, then release your finger.

To arrange applications on the Application screen

- 1 To open the Application screen menu, drag the left edge of the Application screen to the right.
- 2 Select the desired option under **SHOW APPS**.

To search for an application from the Application screen

- 1 To open the Application screen menu, drag the left edge of the Application screen to the right.
- 2 Tap **Search apps**.
- 3 Enter the name of the application you want to search for.

To uninstall an application from the Application screen

- 1 To open the Application screen menu, drag the left edge of the Application screen to the right.
- 2 Tap **Uninstall**. All uninstalleable applications are indicated by .
- 3 Tap the application that you want to uninstall, then tap **Uninstall**.

Navigating applications

You can navigate between applications using the navigation keys, the small apps bar, and the recently used applications window, which lets you switch easily between all recently used applications. Some applications are closed when you press  to exit while others continue to run in the background or pause. If the application is paused or runs in the background, you can continue where you left off the next time you open the application.



- 1 Recently used applications window – Open a recently used application
- 2 Favorites bar – Open a shortcut for applications or widgets
- 3 Task navigation key – Open the recently used applications window and the small apps bar
- 4 Home navigation key – Exit an application and go back to the Home screen
- 5 Back navigation key – Go back to the previous screen within an application or close the application

To open the recently used applications window

- Press .

To close all the recently used applications

- Tap  and then tap **Close all**.

To open a menu in an application

- While using the application, press .
- ! A menu is not available in all applications.

Small apps

A small app is a shortcut used for applications and widgets. You can get quick access to the small apps at any time using the favorites bar. A small app only takes up a small area of your screen, so you can interact with a small app and another application at the same time on the same screen. For example, you can have a web page open and then open the Calculator small app on top of it and perform calculations. You can download more small apps from Google Play™.





To open a small app

- 1 To make the favorites bar appear, press .
- 2 Tap the small app that you want to open.

To close a small app

- Tap  on the small app window.

To download a small app

- 1 From the small apps bar, tap , then tap  and tap .
- 2 Search for the small app that you want to download, then follow the instructions to download it and complete the installation.

To move a small app

- When the small app is open, touch and hold the top left corner of the small app, then move it to the desired location.

To minimize a small app

- When the small app is open, touch and hold the top left corner of the small app, then drag it to the right edge or to the bottom edge of the screen.
- 💡 To minimize a small app, you can also drag down the status bar to open the Notification panel and then tap .

To rearrange the small apps in the small apps bar

- Touch and hold a small app and drag it to the desired position.





To remove a small app from the small apps bar

- Touch and hold a small app, then drag it to .

To restore a previously removed small app

- 1 Open the small apps bar, then tap .
- 2 Touch and hold the small app you want to restore, then drag it into the small apps bar.

To add a widget as a small app

- 1 To make the small apps bar appear, press .
- 2 Tap  >  > .
- 3 Select a widget.
- 4 Enter a name for the widget, if desired, then tap **OK**.

Widgets

Widgets are small applications that you can use directly on your Homescreen. They also function as shortcuts. For example, the Weather widget allows you to see basic weather information directly on your Homescreen. But when you tap the widget, the full Weather application opens. You can download additional widgets from Google Play™.



To add a widget to the Home screen

- 1 Touch and hold an empty area on your Home screen until the device vibrates, then tap **Widgets**.
- 2 Find and tap the widget that you want to add.

To resize a widget

- 1 Touch and hold a widget until it magnifies and the device vibrates, then release the widget. If the widget can be resized, for example, the Calendar widget, then a highlighted frame and resizing dots appear.
- 2 Drag the dots inward or outward to shrink or expand the widget.
- 3 To confirm the new size of the widget, tap anywhere on the Home screen.



To move a widget

- Touch and hold the widget until it magnifies and the device vibrates, then drag it to the new location.

To delete a widget

- Touch and hold the widget until it magnifies and the device vibrates, then drag it to .

To add a widget to the lock screen

- 1 From your Home screen, tap , then find and tap **Settings > Security**
- 2 Mark the **Allow widgets on lock screen** checkbox.
- 3 Press the power key to lock the screen.
- 4 To activate the screen, briefly press the power key .
- 5 Swipe inwards from the middle of the left side of the screen until  appears, then tap it.
- 6 If required, enter your PIN code, pattern or password to unlock the screen.
- 7 Find and tap the widget that you want to add.
- 8 Follow the on-screen instructions, if necessary, to finish adding the widget.

Shortcuts and folders

Use shortcuts and folders to manage your applications and keep your Home screen tidy.



- 1 Access a folder containing applications
- 2 Access an application using a shortcut

To add an application shortcut to your Home screen

- 1 Touch and hold an empty area on your Home screen until the device vibrates and the customization menu appears.
 - 2 In the customization menu, tap **Apps**.
 - 3 Scroll through the list of applications and select an application. The selected application gets added to the Home screen.
-  In step 3, alternatively, you can tap Shortcuts and then select an application from the list available. If you use this method to add shortcuts, some of the applications available allow you to add specific functionality to the shortcut.

To move an item on the Home screen

- Touch and hold the item until it magnifies and the device vibrates, then drag the item to the new location.

To delete an item from the Home screen

- Touch and hold an item until it magnifies and the device vibrates, then drag the item to .

To create a folder on the Home screen

- Touch and hold an application icon or a shortcut until it magnifies and the device vibrates, then drag and drop it on top of another application icon or shortcut.

To add items to a folder on the Home screen

- Touch and hold an item until it magnifies and the device vibrates, then drag the item to the folder.

To rename a folder on the Home screen

- 1 Tap the folder to open it.
- 2 Tap the folder's title bar to show the **Folder name** field.
- 3 Enter the new folder name and tap **Done**.

Background and themes

You can adapt the Home screen to your own style using wallpapers and different themes. You can also change the wallpaper on the lock screen.



To change your Home screen wallpaper

- 1 Touch and hold an empty area on your Home screen until the device vibrates.
- 2 Tap **Wallpapers** and select an option.

To set a theme

- 1 Touch and hold an empty area on your Home screen until the device vibrates.
- 2 Tap **Themes**, then select a theme.

- ! When you change a theme, the background also changes in some applications.

To change the wallpaper for the lockscreen

- 1 From your Homescreen, tap :::
- 2 Find and tap **Settings > Personalization > Lock screen**.
- 3 Select an option, then follow the instructions to change your wallpaper.

Status and notifications

The icons in the status bar inform you of events such as new messages and calendar notifications, activities in progress such as file downloads, and status information such as battery level and signal strength. You can drag down the status bar to open the Notification panel and handle your notifications.

To select which system icons to display in the status bar

- 1 From your Homescreen, tap :::
- 2 Find and tap **Settings > Personalization > Status bar icons**.
- 3 Select the icons you want to display.

To open or close the Notification panel



To select the apps allowed to send notifications

- 1 From your Homescreen, tap \therefore .
- 2 Find and tap **Settings** > **Personalization** > **Manage notifications**.
- 3 Select the apps that are allowed to send notifications.

To take action on a notification

- Tap the notification.

To dismiss a notification from the Notification panel

- Place your finger on a notification and flick left or right.

To clear all notifications from the Notification panel

- Tap **Clear**.

Notification light















A notification light informs you about battery status and other events.



Icons in the status bar

Status icons















	Signal strength
	No signal
	Mobile hotspot is on
	4G LTE is connected
	4G LTE is in use
	Network extender
	Roaming
	3G is available
	Sending and downloading 3G data

-  Battery status
-  The battery is charging
-  STAMINA mode is activated
-  Airplane mode is activated
-  The Bluetooth® function is activated
-  The SIM card is not inserted
-  The SIM card is an unknown SIM
-  The microphone is muted
-  The speakerphone is on
-  Silent mode
-  Vibrate mode
-  An alarm is set
-  GPS is activated
-  Synchronization is ongoing
-  Problem with sign-in or synchronization























! Depending on your service provider, network and/or region, the functions or services represented by some icons in this list may not be available.

Notification icons

The following notification icons may appear on your screen:

-  New email message
-  Email not sent
-  Upcoming calendar event
-  A song is playing
-  The device is connected to a computer via a USB cable
-  Warning message
-  Error message
-  A Wi-Fi® connection is enabled and wireless networks are available
-  Software updates are available
-  Downloading data
-  Uploading data
-  More (undisplayed) notifications
-  Download successful
-  Screenshot

Application overview

-  Use the Alarm and clock application to set various kinds of alarms.
-  Use your web browser to navigate and view web pages, manage bookmarks, and manage text and images.
-  Use the Calculator application to perform basic calculations.
-  Use the Calendar application to keep track of your events and manage your appointments.
-  Use the camera to take photos and record video clips.
-  Use the Contacts application to manage phone numbers, email address and other information related to your contacts.
-  Access your downloaded applications.
-  Use the Email application to send and receive emails through both private and corporate accounts.
-  Use the Album application to view and to work with your photos and videos.
-  Use the Gmail™ application to read, write and organize email messages.
-  Search for information in your device and on the web.
-  View your current location, find other locations, and calculate routes using Google Maps™.
-  Go to Google Play™ to download free and paid applications for your device.
-  Use the Movies application to play videos in your device and share content with your friends.
-  Use the "WALKMAN" application to organize and play music, audio books and podcasts.
-  View news stories and weather forecasts.
-  Use the Video Unlimited application to rent and purchase videos.
-  Optimize settings to suit your own requirements.
-  Use the Hangouts™ application to chat with friends online.
-  Use the Help application to read Get started guide and User guide, get to know icon glossary, view your usage and customize your features of Verizon mobile, and watch help videos and other product-related information.
-  Use YouTube™ to share and view videos from around the world.
-  Download and install new applications and updates.

! Some applications are not supported by all networks and/or service providers in all areas.

Downloading applications

Downloading applications from Google Play™

Google Play™ is the official online Google store for downloading applications, games, music, movies and books. It includes both free and paid applications. Before you start downloading from Google Play™, make sure that you have a working Internet connection, preferably over Wi-Fi® to limit data charges.

- ! To use Google Play™, you need to have a Google™ account. Google Play™ may not be available in all countries or regions.

To download an application from Google Play™

- 1 From the Home screen, tap ☰.
 - 2 Find and tap **Play Store**.
 - 3 Find an item you wish to download by browsing categories, or by using the search function.
 - 4 Tap the item to view its details, and follow the instructions to complete the installation.
- ! Some applications may need to access data, settings and various functions on your device in order to work properly. Only install and give permissions to applications that you trust.
 - 💡 You can view the permissions granted to a downloaded application by tapping the application under Settings > Application manager.

Downloading applications from other sources

When your device is set to allow downloads from sources other than Google Play™, you can download applications directly from other websites by following the relevant download instructions.

- ! Installing applications of unknown or unreliable origin can damage your device. Only download applications from reliable sources. Contact the application provider if you have any questions or concerns.

To allow the download of applications from other sources

- 1 From your Home screen, tap ☰.
 - 2 Find and tap **Settings > Security**.
 - 3 Mark the **Unknown sources** checkbox.
 - 4 Tap **OK**.
- ! Some applications may need to access data, settings and various functions on your device in order to work properly. Only install and give permissions to applications you trust.
 - 💡 You can view the permissions granted to a downloaded application by tapping the application under Settings > Application manager.

Internet and networks

Browsing the web

Use Google Chrome™ for Android™ to browse the web.

To browse with Google Chrome™



- 1 From your Home screen, tap ☰.
- 2 Find and tap .
- 3 If you are using Google Chrome™ for the first time, select to either sign in to a Google™ account or browse with Google Chrome™ anonymously.
- 4 Enter a search term or web address in the search and address field, then tap **Go** on the keyboard.

Wi-Fi®

Use Wi-Fi® connections to surf the Internet, download applications, or send and receive email. Once you have connected to a Wi-Fi® network, your device remembers the network and automatically connects to it the next time you come within range.

Some Wi-Fi® networks require you to log in to a web page before you can get access. Contact the relevant Wi-Fi® network administrator for more information.

Available Wi-Fi® networks may be open or secured:

- Open networks are indicated by  next to the Wi-Fi® network name.
 - Secured networks are indicated by  next to the Wi-Fi® network name.
-  Some Wi-Fi® networks do not show up in the list of available networks because they do not broadcast their network name (SSID). If you know the network name, you can add it manually to your list of available Wi-Fi® networks.

To turn on Wi-Fi®

- 1 From your Home screen, tap ☰.
 - 2 Find and tap **Settings**.
 - 3 Drag the slider beside **Wi-Fi** to the right to turn on the Wi-Fi® function.
-  It may take a few seconds before Wi-Fi® is enabled.

To connect to a Wi-Fi® network automatically

- 1 From your Home screen, tap ☰.
- 2 Find and tap **Settings**.
- 3 Tap **Wi-Fi**. All available Wi-Fi® networks are displayed.
- 4 Tap a Wi-Fi® network to connect to it. For secured networks, enter the relevant password.  is displayed in the status bar once you are connected.

-  To search for new available networks, tap  and then tap **Scan**.

To add a Wi-Fi® network manually

- 1 From your Home screen, tap ☰.
 - 2 Find and tap **Settings** > **Wi-Fi**.
 - 3 Tap **+**.
 - 4 Enter the **Network SSID** information.
 - 5 To select a security type, tap the **Security** field.
 - 6 If required, enter a password.
 - 7 To edit some advanced options such as proxy and IP settings, mark the **Show advanced options** checkbox and then edit as desired.
 - 8 Tap **Save**.
-  Contact your Wi-Fi® network administrator to get the network SSID and password.

Increasing Wi-Fi® signal strength

There are a number of things you can do to increase the strength of a Wi-Fi® signal:

- Move your device closer to the Wi-Fi® access point.
- Move the Wi-Fi® access point away from any potential obstructions or interference.
- Don't cover the Wi-Fi® antenna area of your device (the highlighted area in the illustration).



Wi-Fi® settings

When you are connected to a Wi-Fi® network or when there are Wi-Fi® networks available in your vicinity, it is possible to view the status of these networks. You can also enable your device to notify you whenever an open Wi-Fi® network is detected.

If you are not connected to a Wi-Fi® network, your device requires a mobile data connection to access the Internet. By adding a Wi-Fi® sleep policy, you can specify when to switch from Wi-Fi® to mobile data.

To enable Wi-Fi® network notifications

- 1 Turn on Wi-Fi®, if it is not already on.
- 2 From your Home screen, tap ⋮.
- 3 Find and tap **Settings** > **Wi-Fi**.
- 4 Tap ⋮ > **Advanced**.
- 5 Mark the **Wi-Fi notifications** checkbox.

To view detailed information about a connected Wi-Fi® network

- 1 From the Home screen, tap ⋮.
- 2 Find and tap **Settings** > **Wi-Fi**.
- 3 Tap the Wi-Fi® network that you are currently connected to. Detailed network information is displayed.

To add a Wi-Fi® sleep policy

- 1 From the Home screen, tap ⋮.
- 2 Find and tap **Settings** > **Wi-Fi**.
- 3 Press ⋮.
- 4 Tap **Advanced**.
- 5 Tap **Keep Wi-Fi on during sleep**.
- 6 Select an option.

Sharing your mobile data connection

You can share your device's mobile data connection with a single computer using a USB cable. This process is called USB tethering. Similarly, you can share your device's mobile data connection with other devices with NFC Wi-Fi® tethering or Bluetooth tethering. You can also share your device's mobile data connection by turning your device into a portable Wi-Fi® hotspot. When your device's mobile data connection is successfully

shared, the sharing devices can use your device's data connection, for example, to surf the Internet, download applications, or send and receive emails.

- 💡 You may need to prepare your computer to establish a network connection via USB cable. Go to www.android.com/tether to get the most current information.

To share your data connection using a USB cable

- 1 Deactivate all USB cable connections to your device.
- 2 Using the USB cable that came with your device, connect your device to a computer.
- 3 From your Home screen, tap ⋮.
- 4 Find and tap **Settings > More... > Tethering & Mobile Hotspot**.
- 5 Mark the **Mobile Broadband Connect** checkbox, then tap **OK** if prompted.  is displayed in the status bar once you are connected.
- 6 To stop sharing your data connection, unmark the **Mobile Broadband Connect** checkbox or disconnect the USB cable.



- ! You cannot share both your device's data connection and SD card over a USB cable at the same time.

To share your mobile connection by NFC Wi-Fi® tethering

- 1 Make sure that both devices have the NFC function turned on, and that both screens are active.
- 2 From your Home screen, tap ⋮.
- 3 Find and tap **Settings > More... > Tethering & Mobile Hotspot > NFC Wi-Fi tethering**.
- 4 Tap **OK** if prompted.
- 5 Hold devices back to back so that the NFC detection areas of each device touch each other, and they will connect automatically.

- ! This function only works with devices that also support NFC Wi-Fi tethering.

To use your device as Mobile Hotspot

- 1 From your Home screen, tap ⋮.
- 2 Find and tap **Settings > More... > Tethering & Mobile Hotspot**.
- 3 Tap **Mobile Hotspot settings > Set up Mobile Hotspot**.
- 4 Enter the **Network name (SSID)** information.
- 5 To select a security type, tap the **Security** field. If required, enter a password.
- 6 Tap **Save**.
- 7 Tap  and mark the **Mobile Hotspot** checkbox.
- 8 If prompted, tap **OK** to confirm.  appears in the status bar once the portable Wi-Fi® hotspot is active.
- 9 To stop sharing your data connection via Wi-Fi®, unmark the **Mobile Hotspot** checkbox.

To rename or secure your Mobile Hotspot

- 1 From the Home screen, tap ⋮.
- 2 Find and tap **Settings > More... > Tethering & Mobile Hotspot**.
- 3 Tap **Mobile Hotspot settings > Set up Mobile Hotspot**.
- 4 Enter the **Network name (SSID)** information.
- 5 To select a security type, tap the **Security** field.
- 6 If required, enter a password.
- 7 Tap **Save**.

Controlling data usage

You can keep track of the amount of data transferred to and from your device over your mobile data or Wi-Fi® connection during a given period. For example, you can view the amount of data used by individual applications. For data transferred over your mobile

data connection, you can also set data usage warnings and limits to avoid additional charges.

- ! Adjusting data usage settings can help you keep greater control over data usage but cannot guarantee the prevention of additional charges.

To turn cellular data traffic on or off

- 1 From your Home screen, tap .
- 2 Find and tap **Settings > Data usage**.
- 3 Drag the slider beside **Mobile data traffic** accordingly to turn cellular data traffic on or off.

- 💡 When cellular data traffic is turned off, your device can still establish Wi-Fi® and Bluetooth® connections.

To set a data usage warning

- 1 Make sure cellular data traffic is turned on.
- 2 From your Home screen, tap .
- 3 Find and tap **Settings > Data usage**.
- 4 To set the warning level, drag the warning line to the desired value. You receive a warning notification when the amount of data traffic approaches the level you set.

To set a mobile data usage limit

- 1 Make sure that mobile data traffic is turned on.
- 2 From your Home screen, tap .
- 3 Find and tap **Settings > Data usage**.
- 4 Mark the **Limit mobile data usage** checkbox if it is not marked, then tap **OK**.
- 5 To set the mobile data usage limit, drag the corresponding line to the desired value.



- ! Once your mobile data usage reaches the set limit, mobile data traffic on your device gets turned off automatically.

To control the cellular data usage of individual applications

- 1 From your Home screen, tap .
- 2 Find and tap **Settings > Data usage**.
- 3 Find and tap the desired application.
- 4 Mark the **Restrict background data** checkbox.
- 5 To access more specific settings for the application (if available), tap **View app settings** and make the desired changes.

- 💡 The performance of individual applications may be affected if you change the related data usage settings.

To view data transferred via Wi-Fi®

- 1 From your Home screen, tap .
- 2 Find and tap **Settings > Data usage**.
- 3 Tap , then mark the **Show Wi-Fi usage** checkbox if it is not marked.
- 4 Tap the **Wi-Fi** tab.

Virtual private networks (VPNs)

Use your device to connect to virtual private networks (VPNs), which allow you to access resources inside a secured local network from a public network. For example, VPN connections are commonly used by corporations and educational institutions for users who need to access intranets and other internal services when they are outside of the internal network, for example, when they are traveling.

VPN connections can be set up in many ways, depending on the network. Some networks may require you to transfer and install a security certificate on your device. For detailed information on how to set up a connection to your virtual private network, please contact the network administrator of your company or organization.

To add a virtual private network

- 1 From your Home screen, tap ⋮.
- 2 Find and tap **Settings** > **More...** > **VPN**.
- 3 Tap **+**.
- 4 Select the type of VPN to add.
- 5 Enter your VPN settings.
- 6 Tap **Save**.

To connect to a virtual private network

- 1 From your Home screen, tap ⋮.
- 2 Find and tap **Settings** > **More...** > **VPN**.
- 3 In the list of available networks, tap the VPN you want to connect to.
- 4 Enter the required information.
- 5 Tap **Connect**.

To disconnect from a virtual private network

- 1 Drag the status bar downwards.
- 2 Tap the notification for the VPN connection to turn it off.

Synchronizing data on your device

Synchronizing with online accounts

Synchronize your device with contacts, email, calendar events, and other information from online accounts, for example, email accounts such as Gmail™ and Exchange ActiveSync, Facebook™, Flickr™, and Twitter™. You can synchronize data automatically for all accounts by activating the auto-sync function. Or you can synchronize each account manually.

To set up an online account for synchronization

- 1 From your Home screen, tap ☰.
- 2 Tap **Settings** > **Add account**, then select the account you want to add.
- 3 Follow the instructions to create an account, or sign in if you already have an account.

To activate the auto-sync function

- 1 From your Home screen, tap ☰ > **Settings**.
- 2 Drag the slider beside **Auto-sync** to the right.

To synchronize manually with an online account

- 1 From your Home screen, tap ☰ > **Settings**.
- 2 Under **Accounts**, select the account type, then tap the name of the account you want to synchronize with. A list of items that can be synchronized with the account appears.
- 3 Mark the items you want to synchronize.
- 4 Tap ☰, then tap **Sync now**.

To remove an online account

- 1 From your Home screen, tap ☰ > **Settings**.
- 2 Under **Accounts**, select the account type, then tap the name of the account you want to remove.
- 3 Tap ☰, then tap **Remove account**.
- 4 Tap **Remove account** again to confirm.

Synchronizing with Microsoft® Exchange ActiveSync®

Using a Microsoft Exchange ActiveSync account, you can access your corporate email messages, calendar appointments, and contacts directly on your device. After setup, you can find your information in the **Email**, **Calendar**, and **Contacts** applications.

To set up an EAS account for synchronization

- 1 Make sure you have your domain and server details, provided by your corporate network administrator, available.
 - 2 From your Home screen, tap ☰.
 - 3 Tap **Settings** > **Add account** > **Exchange ActiveSync**.
 - 4 Enter your corporate email address and password.
 - 5 Tap **Next**. Your device begins to retrieve your account information. If a failure occurs, enter the domain and server details for your account manually and then tap **Next**.
 - 6 Tap **OK** to allow your corporate server to control your device.
 - 7 Select what data you want to sync with your device, such as contacts and calendar entries.
 - 8 If desired, activate the device administrator to allow your corporate server to control certain security features on your device. For example, you can allow your corporate server to set password rules and set storage encryption.
 - 9 When the setup is done, enter a name for the corporate account.
- ! When you change the login password for an EAS account on your computer, you have to log in again to the EAS account on your device.

To change the settings of an EAS account

- 1 From your Home screen, tap ☰.
- 2 Tap **Email**, then tap ☰.
- 3 Tap **Settings** and select an EAS account, then change the settings of the EAS account as desired.

To set a synchronization interval for an EAS account

- 1 From your Home screen, tap ☰.
- 2 Tap **Email**, then tap ☰.
- 3 Tap **Settings** and select an EAS account.
- 4 Tap **Account check frequency** > **Check frequency** and select an interval option.

To remove an EAS account

- 1 From your Home screen, tap ☰ > **Settings**.
- 2 Under **Accounts**, tap **Exchange ActiveSync**, then select the EAS account you want to remove.
- 3 Tap ☰, then tap **Remove account**.
- 4 Tap **Remove account** again to confirm.

Basic settings

Accessing settings

View and change settings for your device from the Settings menu. The Settings menu is accessible from both the Application screen and the Quick settings panel.

To open the device settings menu from the Application screen

- 1 From your Home screen, tap .
- 2 Tap **Settings**.

To open the Quick settings panel

- Drag the right side of the status bar downwards.

To select which quick settings to display on the Quick settings panel

- 1 Drag the right side of the status bar downwards, then tap **Edit**.
- 2 Select the quick settings that you want to display.

To rearrange the Quick settings panel

- 1 Drag the right side of the status bar downwards, then tap **Edit**.
- 2 Touch and hold  beside a quick setting, then move it to the desired position.

Sound volume

You can adjust the volume for notifications, music and video playback. You can also set your device to silent mode so that it doesn't sound when you're in a meeting.



To adjust the sound volume with the volume key

- Press the volume key up or down.



To adjust the media playing volume with the volume key

- When playing music or watching video, press the volume key up or down.

To set your device to vibrate mode

- Press the volume key down until  appears in the status bar.
- 💡 You can also press and hold down the power key  and then tap  in the menu that opens to set your device to vibrate mode.

To set your device to silent mode

- 1 Press the volume key down until the device vibrates and  appears in the status bar.
- 2 Press the volume key down again.  appears in the status bar.

To select the notification sound

- 1 From your Home screen, tap .
- 2 Find and tap **Settings > Sound > Notification sound**.
- 3 Select the sound to be played when notifications arrive.
- 4 Tap **Done**.

To enable touch tones

- 1 From your Home screen, tap .
- 2 Find and tap **Settings > Sound**.
- 3 Mark the **Touch sounds** checkbox.

SIM card protection

You can lock and unlock each SIM card that you use in your device with a PIN (Personal Identity Number). When a SIM card is locked, the subscription linked to the card is protected against misuse, meaning that you have to enter a PIN every time you start your device.

If you enter the PIN incorrectly more times than the maximum number of attempts allowed, your SIM card will become blocked. You then need to enter your PUK (Personal Unlocking Key) and a new PIN. Your PIN and PUK are supplied by your network operator.



To lock or unlock a SIM card

- 1 From the Homescreen, tap .
- 2 Find and tap **Settings** > **Security** > **Set up SIM card lock**.
- 3 Mark or unmark the **Lock SIM card** checkbox.
- 4 Enter the SIM card PIN and tap **OK**.

To change the SIM card PIN

- 1 From the Home screen, tap .
- 2 Find and tap **Settings** > **Security** > **Set up SIM card lock**.
- 3 Tap **Change SIM PIN**.
- 4 Enter the old SIM card PIN and tap **OK**.
- 5 Enter the new SIM card PIN and tap **OK**.
- 6 Retype the new SIM card PIN and tap **OK**.

To unlock a blocked SIM card using the PUK code

- 1 Enter the PUK code and tap .
- 2 Enter a new PIN code and tap .
- 3 Re-enter the new PIN code and tap .

- ! If your device requires a PUK code, please contact Verizon Wireless Customer service for the code.

Screen settings

To adjust the screen brightness

- 1 From your Home screen, tap .
- 2 Find and tap **Settings** > **Display** > **Brightness**.
- 3 Unmark the **Adapt to lighting conditions** checkbox if it is marked.
- 4 Drag the slider to adjust the brightness.

-  Lowering the brightness level increases battery performance.

To set the screen to vibrate on touch

- 1 From your Homescreen, tap .
- 2 Find and tap **Settings** > **Sound**.
- 3 Mark the **Vibrate on touch** checkbox. The screen now vibrates when you tap soft keys and certain applications.

To adjust the idle time before the screen turns off

- 1 From your Home screen, tap .
- 2 Find and tap **Settings** > **Display** > **Sleep**.
- 3 Select an option.

-  To turn off the screen quickly, briefly press the power key .

Smart backlight control

The smart backlight control keeps the screen on as long as the device is held in your hand. Once you put down the device, the screen turns off according to your sleep setting.

To turn on the Smart backlight control function

- 1 From your Home screen, tap .
- 2 Find and tap **Settings** > **Display** > **Smart backlight control**.
- 3 Drag the slider beside **Smart backlight control** to the right.

Screen lock

There are several ways to lock the screen. The security level of each lock type is listed below in order of weakest to strongest:

- **Swipe**
 - no protection, but you have quick access to the Home screen
- **Face Unlock**
 - unlocks your device when you look at it
- **Unlock pattern**
 - draw a simple pattern with your finger to unlock your device
- **Unlock PIN**
 - enter a numeric PIN of at least four digits to unlock your device
- **Unlock password**
 - enter an alpha-numeric password to unlock your device

- ! It is very important that you remember your screen unlock pattern, PIN or password. If you forget this information, it may not be possible to restore important data such as contacts and messages.

To set up the Face Unlock feature

- 1 From your Home screen, tap  > **Settings** > **Security** > **Screen lock**.
- 2 Tap **Face Unlock**, then follow the instructions in your device to capture a photo of your face.
- 3 After your face is successfully captured, tap **Continue**.
- 4 Select a backup unlock method and follow the instructions in the device to complete the setup.

-  For best results, capture your face in an indoor area that is well lit but not too bright, and hold the device at eye level.

To unlock the screen using the Face Unlock feature

- 1 Activate the screen.
- 2 Look at your device from the same angle you used to capture your Face Unlock photo.

-  If the Face Unlock feature fails to recognize your face, you must use the backup unlock method to unlock the screen.

To create a screen lock pattern

- 1 From your Homescreen, tap .
- 2 Find and tap **Settings** > **Security** > **Screen lock** > **Pattern**.
- 3 Follow the instructions on your device.

- ! If your lock pattern is rejected five times in a row when you try to unlock your device, you must wait 30 seconds and then try again.

To change the screen lock pattern

- 1 From your Home screen, tap .
- 2 Find and tap **Settings** > **Security** > **Screen lock**.
- 3 Draw your screen unlock pattern.
- 4 Tap **Pattern** and follow the instructions on your device.

To create a screen unlock PIN

- 1 From your Home screen, tap **⋮** > **Settings** > **Security** > **Screen lock** > **PIN**.
- 2 Enter a numeric PIN.
- 3 If necessary, tap **⌵** to minimize the keyboard.
- 4 Tap **Continue**.
- 5 Re-enter and confirm your PIN.
- 6 If necessary, tap **⌵** to minimize the keyboard.
- 7 Tap **OK**.

To create a screen lock password

- 1 From your Home screen, tap **⋮** > **Settings** > **Security** > **Screen lock** > **Password**.
- 2 Enter a password.
- 3 If necessary, tap **⌵** to minimize the keyboard.
- 4 Tap **Continue**.
- 5 Re-enter and confirm your password.
- 6 If necessary, tap **⌵** to minimize the keyboard.
- 7 Tap **OK**.

To change screen lock type

- 1 From your Homescreen, tap **⋮**.
- 2 Find and tap **Settings** > **Security** > **Screen lock**.
- 3 Follow the instructions in your device and select another screen lock type.

Language settings

You can select a default language for your device and change it again at a later time. You can also change the writing language for text input. See *Personalizing the Xperia keyboard* on page 36.

To change the language

- 1 From the Home screen, tap **⋮**.
 - 2 Find and tap **Settings** > **Language & input** > **Language**.
 - 3 Select an option.
 - 4 Tap **OK**.
- ! If you select the wrong language and cannot read the menu texts, find and tap **⊙**. Then select the text beside **⌨** and select the first entry in the menu that opens. You can then select the language you want.

Date and time

You can change the date and time on your device.

To set the date manually

- 1 From the Home screen, tap **⋮**.
- 2 Find and tap **Settings** > **Date & time**.
- 3 Unmark the **Automatic date & time** checkbox, if it is marked.
- 4 Tap **Set date**.
- 5 Adjust the date by scrolling up and down.
- 6 Tap **Set**.

To set the time manually

- 1 From your Home screen, tap **⋮**.
- 2 Find and tap **Settings** > **Date & time**.
- 3 Unmark the **Automatic date & time** checkbox if it is marked.
- 4 Tap **Set time**.
- 5 Scroll up or down to adjust the hour and minute.
- 6 If applicable, scroll up to change **AM** to **PM**, or vice versa.
- 7 Tap **Set**.

To set the time zone

- 1 From your Home screen, tap .
- 2 Find and tap **Settings > Date & time**.
- 3 Unmark the **Automatic time zone** checkbox, if it is marked.
- 4 Tap **Select time zone**.
- 5 Select an option.

Enhancing the sound output

You can enhance the sound of your device by manually enabling individual sound settings such as Clear Phase™ and xLOUD™, or you can let ClearAudio+ technology adjust the sound automatically. You can also enable the Dynamic normalizer so that differences in volume between different media files are minimized.

To enhance the sound output automatically

- 1 From your Homescreen, tap .
- 2 Find and tap **Settings > Sound > Sound effects**.
- 3 Mark the **ClearAudio+** checkbox.

To adjust the sound settings manually

- 1 From the Home screen, tap .
- 2 Find and tap **Settings > Sound > Sound effects**.
- 3 Unmark the **ClearAudio+** checkbox if it is marked.
- 4 Tap **Sound enhancements**.
- 5 Mark or unmark the relevant checkboxes.

To minimize volume differences using the Dynamic normalizer

- 1 From the Homescreen, tap .
- 2 Find and tap **Settings > Sound > Sound effects**.
- 3 Mark the **Dynamic normalizer** checkbox.

Noise cancellation

Your device supports noise-canceling headsets. By using a noise-canceling headset with your device, you can get much clearer audio quality, for example when listening to music in a noisy environment like on a bus, train, or plane. You can also use this feature to create a silent environment in which to study, work, or read.

-  To ensure optimum performance, noise-canceling headsets from Sony are recommended.

To use a noise canceling headset

- 1 Connect the noise canceling headset to your device.
- 2 From your Home screen, tap  > **Settings > Sound > Audio accessories**.
- 3 Select the relevant headset type.
- 4 Tap **Sound effects > Noise canceling**.
- 5 If you want Noise canceling to be enabled only during music or video playback or when the screen is active, select **On (Auto)**.
- 6 If you want Noise canceling to be enabled for as long as the headset is connected, select **On**.

-  When a noise canceling headset is connected to your device, you can also select the noise canceling headset type by dragging down the status bar to open the Notification panel and then tapping Audio accessories.

To adjust the settings to the noise environment

- 1 Make sure a noise-canceling headset is connected to your device.
- 2 From your Homescreen, tap .
- 3 Find and tap **Settings > Sound > Sound effects > Noise environment**.
- 4 Select the noise environment type that applies to your situation, then tap **OK**.

Typing text

On-screen keyboard

You can enter text with the on-screen QWERTY keyboard by tapping each letter individually, or you can use the Gesture input feature and slide your finger from letter to letter to form words. If you prefer to use a smaller version of the on-screen keyboard and enter text using only one hand, you can activate the thumb keyboard or mini keyboard instead.

You can select up to three languages for text input. The keyboard detects the language that you are using and predicts the words for that language as you type.



- 1 Delete a character before the cursor.
- 2 Enter a carriage return or confirm text input.
- 3 Switch between lower-case ⇩, upper-case ⇧ and caps ⇧. For some languages, this key is used to access extra characters in the language.
- 4 Shift to the movable thumb keyboard or mini keyboard.
- 5 Enter text using voice input.
- 6 Enter a space.
- 7 Personalize your keyboard. This key disappears after the keyboard is personalized.
- 8 Display numbers and symbols. For even more symbols, tap &#x20ac;.

To display the on-screen keyboard to enter text

- Tap a text entry field.





To enter text character by character

- 1 To enter a character visible on the keyboard, tap the character.
- 2 To enter a character variant, touch and hold a regular keyboard character to get a list of available options, then select from the list. For example, to enter "é," touch and hold "e" until other options appear, then, while keeping your finger pressed on the keyboard, drag to and select "é."

To enter a period

- After you enter a word, double-tap the space bar.

To switch between the full keyboard and the small keyboards

- 1 When you enter text using the on-screen keyboard, tap , , or .
 - 2 Select a keyboard option.
- 💡 Drag  to move the small keyboard as desired.

To enter text using the Gesture input function

- 1 When the on-screen keyboard is displayed, slide your finger from letter to letter to trace the word that you want to write.
- 2 After you finish entering a word, lift up your finger. A word suggestion appears based on the letters that you have traced.
- 3 If the word that you want does not appear, tap  to see other options and select accordingly. If the desired option does not appear, delete the entire word and trace it again, or enter the word by tapping each letter individually.



To change the Gesture input settings

- 1 When the on-screen keyboard is displayed, tap +=@.
- 2 Tap , then tap **Keyboard settings**> **Text input settings**.
- 3 To activate or deactivate the Gesture input function, mark or unmark the **Gesture input** checkbox.



Entering text using voice input



When you enter text, you can use the voice input function instead of typing the words. Just speak the words that you want to enter. Voice input is an experimental technology from Google™, and is available for a number of languages and regions.

To enable voice input

- 1 When you enter text using the on-screen keyboard, tap +=@.
- 2 Tap , then tap **Keyboard settings**.
- 3 Mark the **Google voice typing key** checkbox.
- 4 Tap  to save your settings. A microphone icon  appears on your on-screen keyboard.

To enter text using voice input

- 1 Open the on-screen keyboard.
- 2 Tap . When  appears, speak to enter text.
- 3 When you're done, tap  again. The suggested text appears.
- 4 Edit the text manually if necessary.

 To make the keyboard appear and enter text manually, tap .



Editing text

You can select, cut, copy, and paste text as you write. You can access the editing tools by double-tapping the entered text. The editing tools then become available via an application bar.

Application bar



- 1 Close the application bar
- 2 Select all text
- 3 Cut text
- 4 Copy text
- 5 Paste text

  only appears when you have text saved on the clipboard.

To select text

- 1 Enter some text, then double-tap the text. The word you tap gets highlighted by tabs on both sides.
- 2 Drag the tabs to the left or right to select more text.

To edit text

- 1 Enter some text, then double-tap the entered text to make the application bar appear.
- 2 Select the text that you want to edit, then use the tools in the application bar to make your desired changes.

Personalizing the Xperia keyboard

When entering text using the on-screen keyboard, you can access keyboard and other text input settings that help you, for example, to set options for writing languages, text prediction and correction, automatic spacing, and quick periods. The keyboard can use data from Email and other applications to learn your writing style. There is also a Personalization guide that runs you through the most basic settings, to get you started quickly.

To access the on-screen keyboard settings

- 1 When you enter text using the on-screen keyboard, tap +=@.
- 2 Tap ✕, then tap **Keyboard settings** and change the settings as desired.
- 3 To add a writing language for text input, tap **Writing languages** and mark the relevant checkboxes.
- 4 Tap **OK** to confirm.

To use your writing style

- 1 When you enter text using the on-screen keyboard, tap +=@.
- 2 Tap ✕, then tap **Keyboard settings** > **Use my writing style** and select a source.

To select a keyboard layout variant

- ! Layout variants are only available for the on-screen keyboard when you select some writing languages and may not be available in all writing languages.
- 1 When you enter text using the on-screen keyboard, tap +=@.
 - 2 Tap ✕, then tap **Keyboard settings**.
 - 3 Tap **Writing languages**, then tap .
 - 4 Select a keyboard layout variant.
 - 5 Tap **OK** to confirm.

Contacts





Transferring contacts

There are several ways to transfer contacts to your new device. Find out more about choosing a transfer method at www.sonymobile.com/support.

Transferring contacts using an online account

If you sync the contacts in your old device or your computer with an online account, for example, Google Sync™, Facebook™, or Microsoft® Exchange ActiveSync®, you can transfer your contacts to your new device using that account.



To synchronize contacts to your new device using a synchronization account

- 1 From your Home screen, tap , then tap .
 - 2 Tap , then tap **Settings > Accounts & sync**.
 - 3 Select the account that you want to sync your contacts with, then tap  > **Sync now**.
- ! You need to be signed in to the relevant sync account before you can sync your contacts with it.

Other methods for transferring contacts

Refer to the User guide of your old device for information about how to copy contacts to a memory card or initiate a transfer of contacts using Bluetooth®.

To import contacts from a memory card

- 1 From your Home screen, tap , then tap .
- 2 Press , then tap **Import contacts > SD card**.
- 3 Select the file that you want to import.

To import contacts using Bluetooth® technology

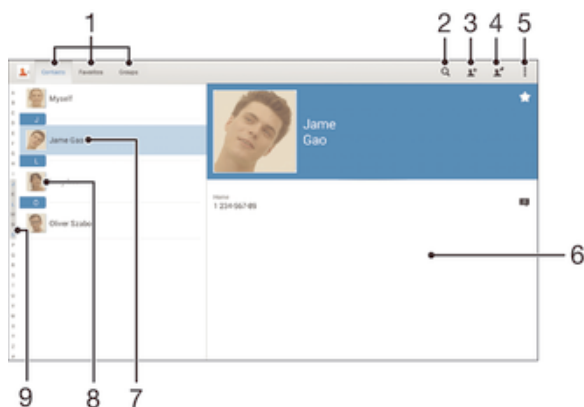

- 1 Make sure you have the Bluetooth® function turned on and that your device is set to visible.
- 2 When you are notified of an incoming file to your device, drag the status bar downward and tap the notification to accept the file transfer.
- 3 Tap **Accept** to start the file transfer.
- 4 Drag the status bar downward. When the transfer is complete, tap the notification.
- 5 Tap the received file.

Searching and viewing contacts





- 1 View your contacts, favorites and groups
- 2 Search for contacts
- 3 Add a contact
- 4 Edit a contact's details
- 5 View more options
- 6 Contact details
- 7 Tap to view a contact's details
- 8 Access communication options for the contact
- 9 Jump to contacts starting with the selected letter

To search for a contact



- 1 From your Home screen, tap , then tap .
- 2 Tap  and enter a phone number, name, or other information in the **Search contacts** field. The result list is filtered as you enter each character.

To select which contacts to display in the Contacts application



- 1 From your Home screen, tap , then tap .
- 2 Tap , then tap **Filter**.
- 3 In the list that appears, mark and unmark the desired options. If you have synchronized your contacts with a synchronization account, that account appears in the list.
- 4 When you are finished, tap **Done**.

Adding and editing contacts





To add a contact

- 1 From your Home screen, tap , then tap .
 - 2 Tap .
 - 3 If you have synchronized your contacts with one or more accounts and you are adding a contact for the first time, you must select the account to which you want to add this contact. Alternatively, tap **Tablet contact** if you only want to use and save this contact on your device.
 - 4 Enter or select the desired information for the contact.
 - 5 When you are finished, tap **Done**.
- ! After you select a synchronization account in step 3, that account will show as the default account offered the next time you add a contact. When you save a contact to a particular account, that account will show as the default account to save to the next time you add a contact. If you have saved a contact to a particular account and want to change it, you need to create a new contact and select a different account to save it to.



To edit a contact

- 1 From your Home screen, tap , then tap .
 - 2 Tap the contact that you want to edit, then tap .
 - 3 Edit the desired information.
 - 4 When you are done, tap **Done**.
- ! Some synchronization services do not allow you to edit contact details.



To associate a picture with a contact

- 1 From your Home screen, tap , then tap .
 - 2 Tap the contact you want to edit, then tap .
 - 3 Tap , and select the desired method for adding the contact picture.
 - 4 When you have added the picture, tap **Done**.
- 💡 You can also add a picture to a contact directly from the Album application.

To delete contacts

- 1 From your Home screen, tap , then tap .
- 2 Touch and hold the contact that you want to delete.
- 3 To delete all contacts, tap the downward arrow to open the drop-down menu, then select **Mark all**.
- 4 Tap , then tap **Delete**.



To edit contact information about yourself

- 1 From your Home screen, tap , then tap .
- 2 Tap **Myself**, then tap .
- 3 Enter the new information or make the changes you want.
- 4 When you are done, tap **Done**.



Favorites and groups

You can mark contacts as favorites so that you can get quick access to them from the Contacts application. You can also assign contacts to groups, to get quicker access to a group of contacts from within the Contacts application.

To mark or unmark a contact as a favorite

- 1 From the Home screen, tap , then tap .
- 2 Tap the contact you want to add to or remove from your favorites.
- 3 Tap .

To view your favorite contacts



- 1 From your Home screen, tap , then tap .
- 2 Tap **Favorites**.

To assign a contact to a group



- 1 In the Contacts application, tap the contact that you want to assign to a group.
- 2 Tap , then tap the bar directly under **Groups**.
- 3 Mark the checkboxes for the groups you want to add the contact to.
- 4 Tap **Done**.

Sending contact information





To send your business card

- 1 From your Home screen, tap , then tap .
- 2 Touch and hold **Myself**.
- 3 Tap , then select a transfer method and follow the on-screen instructions.

To send a contact

- 1 From your Home screen, tap , then tap .
- 2 Touch and hold the contact whose details you want to send.
- 3 Tap , then select a transfer method and follow the on-screen instructions.



To send several contacts at once

- 1 From your Home screen, tap , then tap .
- 2 Press , then tap **Mark several**.
- 3 Mark the contacts you want to send, or select all if you want to send all contacts.
- 4 Tap , then select an available transfer method and follow the on-screen instructions.



Avoiding duplicate entries in the Contacts application

If you synchronize your contacts with a new account or import contact information in other ways, you could end up with duplicate entries in the Contacts application. If this happens, you can join such duplicates to create a single entry. And if you join entries by mistake, you can separate them again later.

To link contacts

- 1 From your Home screen, tap , then tap .
- 2 Tap the contact that you want to link with another contact.
- 3 Press , then tap **Link contact**.
- 4 Tap the contact whose information you want to join with the first contact, then tap **OK** to confirm. The information from the first contact is merged with the second contact, and the linked contacts are displayed as one contact in the Contacts list.

To separate linked contacts

- 1 From your Home screen, tap , then tap .
- 2 Tap the linked contact that you want to edit, then tap .
- 3 Tap **Unlink contact** > **Unlink**.

Backing up contacts

You can use a memory card or an online synchronization tool such as Microsoft® Exchange ActiveSync® to back up contacts.

To export all contacts to a memory card

- 1 From your Home screen, tap , then tap .
- 2 Press , then tap **Export contacts** > **SD card**.
- 3 Tap **OK**.

Email

Setting up email

Use the email application in your device to send and receive email messages through your email accounts. You can have one or several email accounts at the same time, including corporate Microsoft Exchange ActiveSync accounts.

To set up an email account

- 1 From your Home screen, tap \ddots .
 - 2 Find and tap **Email**.
 - 3 Follow the instructions that appear on the screen to complete the setup.
- 💡 For some email services, you may need to contact your email service provider for information on detailed settings for the email account.

To add an extra email account

- 1 From your Home screen, tap \ddots .
- 2 Find and tap **Email**.
- 3 If you are using several email accounts, tap , then tap **Add account**.
- 4 Enter the email address and password, then tap **Next**. If the settings for the email account cannot be downloaded automatically, complete the setup manually.
- 5 When prompted, enter a name for your email account so that it is easily identifiable.
- 6 When you are finished, tap **Next**.

To set an email account as your default account





- 1 From your Home screen, tap \ddots .
 - 2 Find and tap **Email**.
 - 3 Press \mathbb{I} , then tap **Settings**.
 - 4 Select the account you want to use as the default account for composing and sending email messages.
 - 5 Mark the **Default account** checkbox. The inbox of the default account appears every time you open the email application.
- 💡 If you only have one email account, this account is automatically the default account.

Sending and receiving email messages





- 1 View a list of all email accounts and recent folders
- 2 Write an email message
- 3 Search for email messages
- 4 Delete an email message
- 5 Exit an email message
- 6 Access settings and options





To download new email messages

- 1 From your Home screen, tap .
 - 2 Find and tap **Email**.
 - 3 If you are using several email accounts, tap  and select the **Inbox** of the account that you want to check.
 - 4 To download new messages, tap .
-  When the inbox is open, swipe downwards on the screen to refresh the message list.

To read your email messages

- 1 From your Home screen, tap .
- 2 Find and tap **Email**.
- 3 If you are using several email accounts, tap  and select the account that you want to check, then tap **Inbox** in the drop down menu. If you want to check all your email accounts at once, tap , then tap **Combined inbox** in the drop down menu.
- 4 In the email inbox, scroll up or down and tap the email message that you want to read.



To create and send an email message

- 1 From your Home screen, tap , then find and tap **Email**.
- 2 If you are using several email accounts, tap  and select the account from which you want to send the email, then tap **Inbox** in the drop down menu.
- 3 Tap , then type the recipient's name or email address, or tap  and select one or more recipients from your Contacts list.
- 4 Enter the email subject and message text, then tap .

To reply to an email message

- 1 In your email inbox, find and tap the message that you want to reply to, then tap **Reply** or **Reply all**.
- 2 Enter your reply, then tap .

To forward an email message

- 1 In your email inbox, find and tap the message that you want to forward, then tap **Forward**.
- 2 Enter the recipient's email address manually, or tap  and select a recipient from your Contacts list.
- 3 Enter your message text, then tap .

To view an email message attachment

- 1 Find and tap the email message containing the attachment you want to view. Email messages with attachments are indicated by .
- 2 After the email message opens, tap **Load**. The attachment starts to download.
- 3 After the attachment finishes downloading, tap **View**.

To save a sender's email address to your contacts

- 1 Find and tap a message in your email inbox.
- 2 Tap the name of the sender, then tap **OK**.
- 3 Select an existing contact, or tap **Create new contact**.
- 4 Edit the contact information, if desired, then tap **Done**.

Email preview pane

A preview pane is available for viewing and reading your email messages. Once activated, you can use it to view both the email message list and one selected email message at the same time.



To change email preview pane settings

- 1 From your Home screen, tap **:::**, then find and tap **Email**.
- 2 Tap **☰**, then tap **Settings**.
- 3 Tap **General > Split view**.
- 4 Select an option, or a combination of options, then tap **OK**.

To read email messages using the preview pane

- 1 Make sure the preview pane is activated.
- 2 Open your email inbox.
- 3 Scroll up or down and tap the email message that you want to read.
- 4 To view the email message in fullscreen format, tap the split bar (located between the email list and the email body).
- 5 To return to the regular inbox view, tap the split bar again.

Organizing your email messages

To sort your emails

- 1 From your Home screen, tap **:::**.
- 2 Find and tap **Email**.
- 3 If you are using several email accounts, tap **✉** and select the account that you want to sort, then tap **Inbox** in the drop down menu. If you want to sort all your email accounts at once, tap **✉**, then tap **Combined inbox**.
- 4 Tap **☰**, then tap **Sort**.
- 5 Select a sorting option.

To search for emails

- 1 From your Home screen, tap **:::**, then find and tap **Email**.
- 2 If you are using several email accounts, tap **✉** and select the name of the account that you want to check, then tap **Inbox** in the drop down menu. If you want to search all your email accounts at once, tap **✉**, then tap **Combined view**.
- 3 Tap **Q**.
- 4 Enter your search text, then tap **Q** on the keyboard.
- 5 The search result appears in a list sorted by date. Tap the email message that you want to open.

To view all folders for one email account

- 1 From your Home screen, tap **:::**, then find and tap **Email**.
- 2 If you are using several email accounts, tap **✉**, and select the account you want to check.
- 3 Under the account that you want to check, select **Show all folders**.

To delete an email message

- 1 In your email inbox, mark the checkbox for the message that you want to delete, then tap **🗑**.
 - 2 Tap **Delete**.
- 💡 In the email inbox view, you can also flick a message to the right to delete it.

Email account settings

To remove an email account from your device

- 1 From your Home screen, tap ☰.
- 2 Find and tap **Email**.
- 3 Press ⋮, then tap **Settings**.
- 4 Select the account you want to remove.
- 5 Tap **Delete account** > **OK**.

To change the inbox check frequency

- 1 From your Home screen, tap ☰.
- 2 Find and tap **Email**.
- 3 Tap ⋮, then tap **Settings**.
- 4 Select the account for which you want to change the inbox check frequency.
- 5 Tap **Inbox check frequency** > **Check frequency** and select an option.

To set an Out of Office auto-reply in an Exchange Active Sync account

- 1 From your Home screen, tap ☰, then find and tap **Email**.
- 2 Press ⋮, then tap **Settings**.
- 3 Select the EAS (Exchange Active Sync) account for which you want to set an Out of Office auto-reply.
- 4 Tap **Out of office**.
- 5 Drag the slider beside **Out of office** to the right to turn on the function.
- 6 If needed, mark the **Set time range** checkbox and set the time range for the auto reply.
- 7 Enter your Out of Office message in the body text field.
- 8 Tap **OK** to confirm.

Gmail™

If you have a Google™ account, you can use the Gmail™ application to read and write email messages.



- 1 Name of the current folder and account
- 2 Write a new email message
- 3 Search for email messages
- 4 Access settings and options
- 5 List of email messages
- 6 View a list of all Gmail accounts and folders

To learn more about Gmail™

- When the Gmail application is open, tap ⋮, then tap **Help**.

Music

Transferring music to your device

Using this way to get music from a computer onto your device:

- Connect the device and computer using a USB cable and drag and drop music files directly into the file manager application on the computer. See *Managing files using a computer* on page 90.
- ! The "WALKMAN" application may not support all music file formats. For more information about supported file formats and the use of multimedia (audio, image and video) files, download the White Paper for your device at www.sonymobile.com/support.

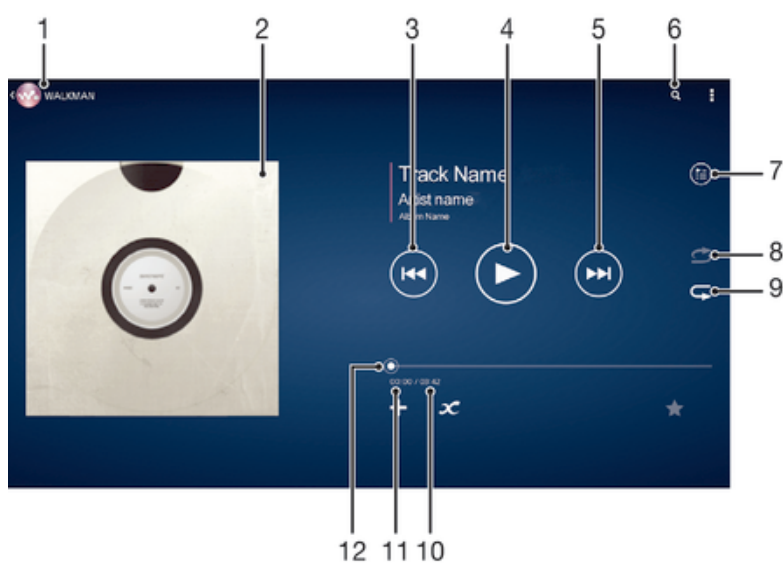

Listening to music

Use the "WALKMAN" application to listen to your favorite music and audio books.





- 1 Browse your music
- 2 Album art (if available)
- 3 Tap to go to the previous song in the play queue Touch and hold to rewind within the current song
- 4 Play or pause a song
- 5 Tap to go to the next song in the play queue Touch and hold to fast forward within the current song
- 6 Search songs on Music Unlimited and all songs saved to your device
- 7 View the current play queue
- 8 Shuffle songs in the current play queue
- 9 Repeat all songs in the current play queue
- 10 Total time length of current song
- 11 Elapsed time of current song
- 12 Progress indicator – Drag the indicator or tap along the line to fast forward or rewind

To play a song using the “WALKMAN” application

- 1 From your Home screen, tap , then find and tap .
- 2 If the “WALKMAN” homescreen is not displayed, tap , then drag the left edge of the “WALKMAN” homescreen to the right. If the “WALKMAN” homescreen is displayed, drag the left edge of the “WALKMAN” homescreen to the right.
- 3 Select a music category, for example, under **Artists**, **Albums**, or **Songs**, then browse to the song that you want to open.
- 4 Tap a song to play it.

! You might not be able to play copyright-protected items. Please verify that you have necessary rights in material that you intend to share.

To find song-related information online

- While a song is playing in the "WALKMAN" application, tap the infinite button .
- 💡 The infinite button  gives you access to several sources of information including videos on YouTube™, lyrics, and artist info on Wikipedia.

To adjust the audio volume

- Press the volume key.

To minimize the "WALKMAN" application

- When a song is playing, tap  to go to the Home screen. The "WALKMAN" application stays playing in the background.

To open the "WALKMAN" application when it is playing in the background

- 1 While a song is playing in the background, tap the  to open the recently used applications window.
- 2 Tap the "WALKMAN" application.

“WALKMAN” homescreen menu

The “WALKMAN” homescreen menu gives you an overview of all the songs on your device as well as of the songs available on Music Unlimited. From here you can manage your albums and playlists, create shortcuts, and organize your music by mood and tempo using SensMe™ channels.

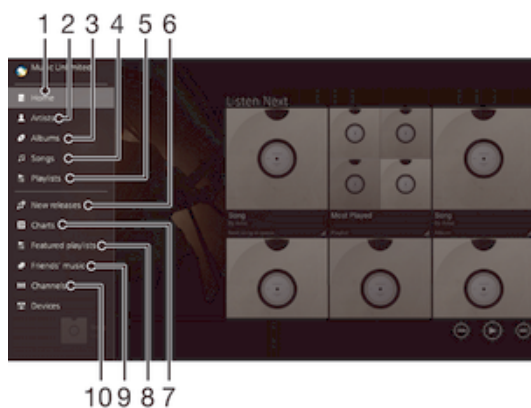

- 1 Return to the “WALKMAN” homescreen
- 2 Browse your music by artist
- 3 Browse your music by album
- 4 Browse your music by song
- 5 Browse all playlists
- 6 New releases (provided by Music Unlimited)
- 7 Charts (provided by Music Unlimited)



8 Featured playlists (provided by Music Unlimited)

9 Collect links to music and related content that you and friends have shared using online services

10 Manage and edit your music using Music Unlimited channels

- ! Sony Entertainment Network with Video Unlimited and Music Unlimited is not available in every market. Separate subscription required. Additional terms and conditions apply.

To open the “WALKMAN” homescreen menu

- 1 From your Home screen, tap , then find and tap .
- 2 If the “WALKMAN” homescreen is not displayed, tap , then drag the left edge of the “WALKMAN” homescreen to the right. If the “WALKMAN” homescreen is displayed, drag the left edge of the “WALKMAN” homescreen to the right.

To return to the “WALKMAN” homescreen

- When the “WALKMAN” homescreen menu is open, tap **Home**.
- When the “WALKMAN” homescreen menu is open, tap on the screen to the right of the menu.

To update your music with the latest information

- 1 From the “WALKMAN” homescreen, tap .
- 2 Tap **Download music info > Start**. Your device searches online and downloads the latest available album art and song information for your music.

- 💡 The SensMe™ channels application is activated when you download music information.

To enable the SensMe™ channels application

- From the “WALKMAN” homescreen, tap , then tap **Download music info > Start**.

- ! This application requires a cellular or Wi-Fi® network connection.

To delete a song

- 1 From the “WALKMAN” homescreen, browse to the song that you want to delete.
- 2 Touch and hold the song title, then tap **Delete** from the list that appears.
- 3 Tap **Delete** again to confirm.

- 💡 You can also delete albums this way.

Playlists

On the “WALKMAN” homescreen, you can create your own playlists from the music that is saved on your device.

To create your own playlists

- 1 From the “WALKMAN” homescreen, touch and hold the name of the album or song that you want to add to a playlist.
- 2 In the menu that opens, tap **Add to > Create new playlist**.
- 3 Enter a name for the playlist and tap **OK**.

- 💡 You can also tap the album art and then tap **+** to create a new playlist.

To play your own playlists

- 1 Open the “WALKMAN” homescreen menu, then tap **Playlists**.
- 2 Under **Playlists**, select the playlist that you want to open.
- 3 If you want to play only one song in the playlist, tap the name of the song. If you want to play all songs, tap **Shuffle all**.

To add songs to a playlist

- 1 From the "WALKMAN" homescreen, browse to the song or album that you want to add to a playlist.
- 2 Touch and hold the song or the album title, then tap **Add to**.
- 3 Tap the name of the playlist you want to add the album or song to. The album or song is added to the playlist.

To remove a song from a playlist

- 1 In a playlist, touch and hold the title of the song you want to delete.
- 2 Tap **Delete from playlist** from the list that appears.

To delete a playlist

- 1 Open the "WALKMAN" homescreen menu, then tap **Playlists**.
- 2 Touch and hold the playlist that you want to delete.
- 3 Tap **Delete**.
- 4 Tap **Delete** again to confirm.

! You cannot delete default playlists.

Sharing music

To share a song

- 1 From the "WALKMAN" homescreen, browse to the song or album that you want to share.
- 2 Touch and hold the song title, then tap **Share**.
- 3 Select an application from the list, then follow the on-screen instructions.

💡 You can also share albums and playlists in the same way.

Sharing music on Facebook™

The Friends' music function collects links to music and music-related content that you and your friends have shared using Facebook™.

To share and "Like" a song on Facebook™

- 1 While the song is playing in the "WALKMAN" application, tap  to show that you "Like" the song on Facebook™. If desired, add a comment in the comments field.
- 2 Tap **Share** to send the song to Facebook™. If the song is received successfully, you will get a confirmation message from Facebook™.

To manage music from your friends on Facebook™

- 1 Open the "WALKMAN" homescreen menu, then tap **Friends' music > Recent**.
- 2 Tap an item that you want to work on.
- 3 Manage the item as desired. For example, to "Like" the song, tap . To comment on the song, add a comment in the comments field.

To view music that you shared on Facebook™

- 1 Open the "WALKMAN" homescreen menu, then tap **Friends' music > My shares**.
- 2 Scroll to an item that you want to open, then tap it. All comments that you posted on Facebook™ about the item, if any, are displayed.

Enhancing the sound

To improve the sound quality using the Equalizer

- 1 When a song is playing in the "WALKMAN" application, tap .
- 2 Tap **Settings > Sound effects > Sound enhancements**.
- 3 To adjust the sound manually, drag the frequency band buttons up or down. To adjust the sound automatically, tap  and select a style.



To turn on the Surround sound feature

- 1 When the Walkman® application is open, tap .
- 2 Tap **Settings** > **Sound effects** > **Sound enhancements** > **Surround sound (VPT)**.
- 3 Select a setting, then tap **OK** to confirm.



Visualizer

The Visualizer adds visual effects to your songs as you play them. The effects for each song are based on the characteristics of the music. They change, for example, in response to changes in the music's volume, rhythm, and frequency level. You can also change the background theme.

To turn on the Visualizer

- 1 In the "WALKMAN" application, tap .
 - 2 Tap **Visualizer**.
-  Tap the screen to switch to full-screen view.

To change the background theme

- 1 In the "WALKMAN" application, tap .
- 2 Tap **Visualizer**.
- 3 Tap  > **Theme** and select a theme.

Music Unlimited online service

Music Unlimited is a subscription-based service that offers access to millions of songs over a mobile network or Wi-Fi® connection. You can manage and edit your personal music library in the cloud from a variety of devices, or sync your playlists and music using a PC that runs the Windows® operating system. Go to www.sonyentertainmentnetwork.com for more information.

-  Sony Entertainment Network with Video Unlimited and Music Unlimited is not available in every market. Separate subscription required. Additional terms and conditions apply.

To get started with Music Unlimited

- 1 From the "WALKMAN" homescreen, tap  > **Settings**.
- 2 Drag the slider beside **Music Unlimited** to the right so that the **Music Unlimited** function gets turned on, then follow the on-screen instructions.

Camera

Taking photos and recording videos



- 1 Zoom in or out
- 2 Front camera
- 3 Main camera screen
- 4 Take photos or record video clips
- 5 Capturing mode settings icon
- 6 Go back a step or exit the camera
- 7 Switch between front and main camera
- 8 Display all settings

To take a photo from the lock screen

- 1 To activate the screen, briefly press the power key (⏻).
- 2 To activate the camera, touch and hold and drag upwards.
- 3 After the camera opens, tap .

To take a photo by touching the screen

- 1 Activate the camera.
- 2 Tap , then tap .
- 3 Drag the slider beside **Touch capture** to the right.
- 4 Point the camera towards the subject.
- 5 To activate auto focus, touch and hold a spot on the screen. When the focus frame turns blue, lift your finger to take the photo.



To take a photo by tapping the on-screen camera button

- 1 Activate the camera.
- 2 Point the camera toward the subject.
- 3 Tap the on-screen camera button . The photo is taken as soon as you release your finger.

To take a self-portrait using the front camera

- 1 Activate the camera.
- 2 Tap .
- 3 To take the photo, tap the on-screen camera button . The photo is taken as soon as you release your finger.

To record a video by tapping the screen



- 1 Activate the camera.
- 2 Point the camera toward the subject.
- 3 Tap  to start recording.
- 4 Tap  to stop recording.

! This function is only available in Superior auto capturing mode.

To view your photos and videos

- 1 Activate the camera, then tap a thumbnail to open a photo or video.
- 2 Flick left or right to view your photos and videos.





To delete a photo or recorded video

- 1 Browse to the photo or video that you want to delete.
- 2 Tap the screen to make  appear.
- 3 Tap .
- 4 Tap **Delete** to confirm.

Face detection

You can use face detection to bring an off-center face into focus. The camera automatically detects up to five faces, indicated by white frames. A yellow frame shows which face has been selected for focus. Focus is set to the face closest to the camera. You can also tap one of the frames to select which face should be in focus.

To turn on face detection

- 1 Activate the camera.
- 2 Tap , then select .
- 3 Tap , then tap .
- 4 Tap **Focus mode** > **Face detection**.

To take a photo using face detection

- 1 When the camera is open and **Face detection** turned on, point the camera at your subject. Up to five faces can be detected, and each detected face is framed.
- 2 Tap the frame you want to select for focus. Do not tap if you want the camera to select focus automatically.
- 3 A yellow frame shows which face is in focus. Tap the screen to take the photo.

Using Smile Shutter™ to capture smiling faces

Use Smile Shutter™ technology to photograph a face just as it smiles. The camera detects up to five faces and selects one face for smile detection and auto-focus. When the selected face smiles, the camera automatically takes a photo.

To turn on Smile Shutter™



- 1 Activate the camera.
- 2 Tap , then tap .
- 3 Tap **Smile Shutter** and select a smile level.

To take a photo using Smile Shutter™



- 1 When the camera is open and Smile Shutter™ is turned on, point the camera at your subject. The camera selects which face to focus on.
- 2 The face selected appears inside a colored frame and the photo is taken automatically.
- 3 If no smile is detected, tap the screen to take the photo manually.

Adding the geographical position to your photos

Turn on geotagging to add the approximate geographical location (a geotag) to photos when you take them. The geographical location is determined either by wireless networks (mobile or Wi-Fi® networks) or GPS technology.









When  appears on the camera screen, geotagging is turned on but the geographical position has not been found. When  appears, geotagging is turned on and the geographical location is available, so your photo can get geotagged. When neither of these two symbols appear, geotagging is turned off.

To turn on geotagging

- 1 From your Home screen, tap .
- 2 Tap **Settings** > **Location**.
- 3 Drag the slider beside **Location** to the right.
- 4 Activate the camera.
- 5 Tap , then tap .
- 6 Drag the slider beside **Geotagging** to the right.
- 7 Tap **OK**.

General camera settings

Capturing mode settings overview

-  **Superior auto**
Optimize your settings to suit any scene.
-  **Manual**
Adjust camera settings manually.
-  **Social live**
Broadcast live video to Facebook™.
-  **Timeshift burst**
Find the best photo from a burst of images.
-  **AR effect**
Take photos with virtual scenes and characters.
-  **Creative effect**
Apply effects to photos or videos.
-  **Sweep Panorama**
Use this setting to take wide-angle, panoramic photos. Just tap the screen and move the camera steadily from one side to the other.
-  **Background defocus**
Blur the background of your photos to make your subject look sharper in comparison.

Superior auto

Superior auto mode detects the conditions you are shooting in and automatically adjusts the settings to ensure you take the best photo possible.

Manual mode

Use Manual mode when you want to manually adjust your camera settings for photos and videos.

Background defocus mode

Use your camera's blurred background effect to make your subjects look sharper and more vivid in comparison with their background. In Background defocus mode, the camera takes two shots, identifies the background and then blurs it while keeping the subject sharp and in focus. It's just like shooting with a digital SLR camera. You can select from three different blur variations and tune the blur level in the preview display.

AR effect

You can apply AR (augmented reality) effects to your photos and make them more fun. This setting lets you integrate 3D scenes into your photos as you take them. Just select the scene you want and adjust its position in the viewfinder.



Creative effect

You can apply different effects on your photos or videos. Add a Nostalgic effect to make photos look older, or a Sketch effect for a more fun image.

Timeshift burst

The camera takes a burst of 61 photos in a window of two seconds – one second before and after you press the camera key. So you can go back and find the perfect image.





To use Timeshift burst

- 1 Activate the camera.
- 2 Tap , then select .
- 3 To take photos, press the camera key fully down and then release it. The photos taken appear in thumbnail view.
- 4 Scroll through the thumbnails and select the photo that you want to save, then tap .

Social live

Social live is a camera shooting mode that lets you stream video live to your Facebook™ page. You just need to have an active internet connection and be logged into Facebook™. Videos can be up to 10 minutes long.

To broadcast live video using Social live

- 1 Activate the camera.
- 2 Tap , then select .
- 3 Log in to your Facebook™ account.
- 4 Tap  to start broadcasting.
- 5 To take a photo during the broadcast, tap .
- 6 To stop broadcasting, tap .

Quick launch

Use Quick launch settings to launch the camera when the screen is locked.

Launch only

After you drag  inwards, the main camera is launched from sleep mode.

Launch and capture

After you drag  inwards, the still camera is launched from sleep mode and a photo is captured.

Launch and record video

After you drag  inwards, the video camera is launched from sleep mode and starts recording.

Off

Geotagging

Tag photos with details of where you took them.

Touch capture

Identify a focus area, and then touch the camera screen with your finger. The photo is taken as soon as you release your finger.

Shutter sound

Choose to turn the shutter sound on or off.

Data storage

You can choose to save your data either to a removable SD card or to your device's internal storage.

Internal storage

Photos or videos are saved on the device memory.

SD card

Photos or videos are saved on the SD card.

White balance

This function adjusts the color balance according to the lighting conditions. The white balance setting icon  is available on the camera screen.



Auto

Adjusts the color balance automatically to suit the lighting conditions.



Incandescent

Adjusts the color balance for warm lighting conditions, such as under light bulbs.



Fluorescent

Adjusts the color balance for fluorescent lighting.



Daylight

Adjusts the color balance for sunny outdoor conditions.



Cloudy

Adjusts the color balance for a cloudy sky.

! This setting is only available in Manual capturing mode.

Still camera settings

To adjust the still camera settings

- 1 Activate the camera.
- 2 To display all settings, tap .
- 3 Select the setting you want to adjust, then edit as desired.

Still camera settings overview

Resolution

Choose between several resolutions and aspect ratios before taking a photo. A photo with a higher resolution requires more memory.

8MP

3264×2448(4:3)

8-megapixel resolution with 4:3 aspect ratio. Suitable for photos you want to view on non-widescreen displays or print in high resolution.

5MP

3104×1746(16:9)

5 megapixel picture size with 16:9 aspect ratio. Suitable for photos you want to view on non-widescreen displays or print in high resolution.

3MP

2048×1536(4:3)

3-megapixel resolution with 4:3 aspect ratio. Suitable for photos you want to view on non-widescreen displays or print in high resolution.

2MP

1920×1080(16:9)

2-megapixel resolution with 16:9 aspect ratio. Suitable for photos you want to view on widescreen displays.

! This setting is only available in Manual capturing mode.

Self timer

With the self-timer you can take a photo without holding the device. Use this function to take self-portraits, or group photos where everyone can be in the photo. You can also use the self-timer to avoid shaking the camera when taking photos.

On (10 sec.)

Set a 10-second delay from when you tap the camera screen until the photo is taken.

On (2 sec.)

Set a 2-second delay from when you tap the camera screen until the photo is taken.

Off

The photo is taken as soon as you tap the camera screen.

Smile Shutter™

Use the Smile Shutter™ function to determine what kind of smile the camera reacts to before taking a photo.

Focus mode

The focus function controls which part of a photo should be sharp. When continuous autofocus is on, the camera keeps adjusting focus so that the area within the yellow focus frame stays sharp.

Single autofocus

The camera automatically focuses on the selected subject. Continuous autofocus is on. Touch and hold the camera screen until the yellow focus frame turns blue, indicating that the focus is set. The photo is taken when you release your finger.

Multi autofocus

The focus is automatically set on several areas of the image. Touch and hold the camera screen until the yellow focus frame turns blue, indicating that the focus is set. The photo is taken when you release your finger. Continuous autofocus is off.

Face detection

The camera automatically detects up to five human faces, indicated by frames on the screen. The camera automatically focuses on the nearest face. You can also select which face to focus on by tapping it on the screen. When you tap the camera screen, a blue frame shows which face is selected and in focus. Face detection cannot be used for all scene types. Continuous autofocus is on.

Touch focus

Touch a specific area on the camera screen to set the area of focus. Continuous autofocus is off. Touch and hold the camera screen until the yellow focus frame turns blue, indicating that the focus is set. The photo is taken when you release your finger.

Object tracking

When you select an object by touching it in the viewfinder, the camera tracks it for you.

! This setting is only available in Manual capturing mode.

HDR

Use the HDR (High Dynamic Range) setting to take a photo against strong backlight or in conditions where the contrast is sharp. HDR compensates for the loss of detail and produces a picture that is representative of both dark and bright areas.

! This setting is only available in Manual capturing mode.

ISO

You can reduce image blurring caused by dark conditions or moving subjects by increasing the ISO sensitivity.

Auto

Sets the ISO sensitivity automatically.

50

Sets the ISO sensitivity to 50.

100

Sets the ISO sensitivity to 100.

200

Sets the ISO sensitivity to 200.

400

Sets the ISO sensitivity to 400.

800

Sets the ISO sensitivity to 800.

1600

Sets the ISO sensitivity to 1600.

- ! This setting is only available in Manual capturing mode.

Metering

This function automatically determines a well-balanced exposure by measuring the amount of light striking the image you want to capture.

Center

Adjusts the exposure to the center of the image.

Average

Calculates the exposure based on the amount of light striking the whole image.

Spot

Adjusts the exposure in a very small part of the image that you want to capture.

- ! This setting is only available in Manual capturing mode.

Image stabilizer

When taking a photo, it can be difficult to hold the device steady. The stabilizer helps you by compensating for small movements of the hand.

- ! This setting is only available in Manual capturing mode.

Preview

You can choose to preview photos or videos just after you shoot them.

Unlimited

The preview of the photo or video appears after you shoot it.

5 seconds

The preview of the photo or video appears for 5 seconds after you shoot it.

3 seconds

The preview of the photo or video appears for 3 seconds after you shoot it.

Edit

The photo or video opens for editing after you shoot it.

Off

















The photo or video is saved after you shoot it, and no preview appears.

Face registration

You can register faces with the Camera application so that the viewfinder automatically focuses on these faces when they appear in the viewfinder.

Scene selection

Use the Scene selection feature to quickly set up the camera for common situations using pre-programmed scenes. The camera determines a number of settings for you to fit the selected scene, ensuring the best possible photo.

- SCN Off**
The Scene selection feature is off and you can take photos manually.
-  **Soft skin**
Take photos of faces using an enhanced beauty effect.
-  **Soft snap**
Use for shooting photos against a soft background.
-  **Anti motion blur**
Use for minimizing camera shake when shooting a slightly dark scene.
-  **Landscape**
Use for landscape photos. The camera focuses on distant objects.
-  **Backlight correction HDR**
Use to improve details in high contrast shots. The built-in backlight correction analyzes the image and automatically adjusts it to give you a perfectly lit shot.
-  **Night portrait**
Use for portrait photos taken at night or in poorly lit environments. Due to the long exposure time, the camera must be held still or placed on a stable surface.
-  **Night scene**
Use when taking photos at night or in poorly lit environments. Due to the long exposure time, the camera must be held still or placed on a stable surface.
-  **Hand-held twilight**
Use for taking hand-held low-light photos with reduced noise and blur.
-  **High sensitivity**
Use for taking photos without a flash under low light conditions. Reduces blur.
-  **Gourmet**
Use for shooting food arrangements in bright color.
-  **Pet**
Use for taking photos of your pet. Reduces blur and red eyes.
-  **Beach**
Use for taking photos of seaside or lakeside scenes.
-  **Snow**
Use in bright environments to avoid overexposed photos.
-  **Party**
Use for indoor photos in poorly lit environments. This scene picks up indoor background lighting or candlelight. Due to the long exposure time, the camera must be held still or placed on a stable surface.
-  **Sports**
Use for taking photos of fast-moving objects. Short exposure time minimizes motion blurring.
-  **Document**
Use for photos of text or drawings. Gives the photo increased, sharper contrast.
-  **Fireworks**
Use for taking photos of fireworks in all their glory.

! This setting is only available in Manual capturing mode.

Video camera settings

To adjust the video camera settings

- 1 Activate the camera.
- 2 Tap one of the settings icons on the screen.
- 3 To display all settings, tap .
- 4 Select the setting that you want to adjust, then make your changes.

Video camera settings overview

Video resolution

Adjust the video resolution for different formats.

Full HD**1920×1080(16:9)**

Full HD (Full High Definition) format with 16:9 aspect ratio. 1980×1080 pixels.

HD**1280×720(16:9)**

HD (High Definition) format with 16:9 aspect ratio. 1280×720 pixels.

VGA**640×480(4:3)**

VGA format with 4:3 aspect ratio.

MMS

Record videos suitable for sending in multimedia messages. The recording time of this video format is limited so that video files can fit in a multimedia message.

- ! This setting is only available in Manual capturing mode.

Self timer

With the self-timer you can record a video without holding the device. Use it to record group videos where everyone can be in the video. You can also use the self-timer to avoid shaking the camera when recording videos.

On (10 sec.)

Set a 10-second delay from when you tap the camera screen until the video begins to record.

On (2 sec.)

Set a 2-second delay from when you tap the camera screen until the video begins to record.

Off

The video begins to record as soon as you tap the camera screen.

Smile Shutter™(video)

Use the Smile Shutter™ function to determine what kind of smile the camera reacts to before recording a video.

Focus mode

The focus setting controls which part of a video should be sharp. When continuous autofocus is on, the camera keeps adjusting focus so that the area within the white focus frame stays sharp.

Single autofocus

The camera automatically focuses on the selected subject. Continuous autofocus is on.

Face detection

The camera automatically detects up to five human faces, indicated by frames on the screen. The camera automatically focuses on the nearest face. You can also select which face to focus on by tapping it on the screen. When you tap the camera screen, a yellow frame shows which face is selected and in focus. Face detection cannot be used for all scene types. Continuous autofocus is on.

Object tracking

When you select an object by touching it in the viewfinder, the camera tracks it for you.

- ! This setting is only available in Manual capturing mode.

HDR video

Use the video HDR (High-Dynamic Range) setting to record a video against strong backlight or in conditions where the contrast is sharp. Video HDR compensates for the loss of detail and produces a picture that is representative of both dark and bright areas.

- ! This setting is only available in Manual capturing mode.

Metering

This function automatically determines a well-balanced exposure by measuring the amount of light striking the image you want to capture.

Center

Adjusts the exposure to the center of the image.

Average

Calculates the exposure based on the amount of light striking the whole image.

Spot

Adjusts the exposure in a very small part of the image that you want to capture.

! This setting is only available in Manual capturing mode.

SteadyShot™

When recording a video, it can be difficult to hold the device steady. The stabilizer helps you by compensating for small movements of the hand.

Microphone

Select whether to pick up the surrounding sound when recording videos.

Preview

You can choose to preview videos just after you shoot them.

On

The preview of the video appears after you shoot it.

Edit

The video opens for editing after you shoot it.

Off

The video is saved after you shoot it, and no preview appears.

Scene selection

The Scene selection feature helps you quickly set up the camera for common situations using pre-programmed video scenes. The camera determines a number of settings for you to fit the selected scene, ensuring the best possible video.

SCN Off

The Scene selection feature is off and you can shoot videos manually.



Soft snap

Use for shooting videos against soft backgrounds.



Landscape

Use for videos of landscapes. The camera focuses on distant objects.



Night

When turned on, light sensitivity is increased. Use in poorly lit environments. Videos of fast moving objects may get blurred. Hold your hand steady, or use a support. Turn off night mode when lighting conditions are good to improve the video quality.



Beach

Use for videos of seaside or lakeside scenes.



Snow

Use in bright environments to avoid overexposed videos.



Sports

Use for videoing fast-moving objects. Short exposure time minimizes motion blurring.



Party

Use for indoor videos in poorly lit environments. This scene picks up indoor background lighting or candlelight. Videos of fast moving objects may get blurred. Hold your hand steady, or use a support.

! This setting is only available in Manual capturing mode.

Photos and videos in Album

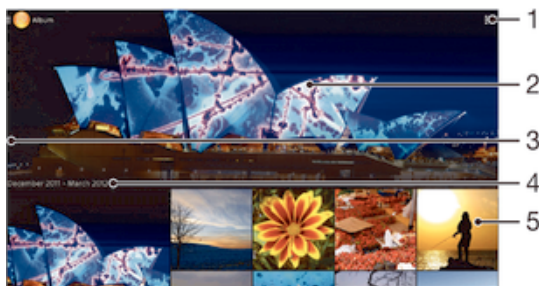

Viewing photos and videos

Use the Album application to view photos and play videos that you've taken with your camera, or to view similar content that you've saved to your device. All photos and videos are displayed in a chronologically ordered grid.



- 1 View menu options
- 2 Scroll up or down to view content
- 3 Drag the left edge of the screen to the right to open the Album homescreen menu
- 4 The date of items in the group
- 5 Tap a photo or video to view it

To view photos and videos

- 1 From your Home screen, tap .
 - 2 Find and tap **Album**.
 - 3 Tap a photo or video to view it.
 - 4 Flick left to view the next photo or video. Flick right to view the previous photo or video.
-  If the screen orientation does not change automatically when you turn your device sideways, mark the Auto-rotate screen checkbox under Settings > Display.

To change the size of the thumbnails

- When viewing thumbnails of photos and videos in Album, spread two fingers apart to zoom in, or pinch two fingers together to zoom out.



To zoom a photo

- When you are viewing a photo, spread two fingers apart to zoom in, or pinch two fingers together to zoom out.

To watch a slideshow of your photos

- 1 When you are viewing a photo, tap the screen to display the toolbars, then tap  > **Slideshow** to start playing all the photos in an album.
- 2 Tap a photo to end the slideshow.

To watch a slideshow of your photos with music

- 1 When you are viewing a photo, tap the screen to display the toolbars, then tap  > **SensMe™ slideshow**.
- 2 Select the music and theme that you want to use for the slideshow, then tap . The Album application analyses your photos and uses SensMe™ music data to play a slideshow.
- 3 To pause playing, tap the screen to display the controls, then tap .

To play a video

- 1 In Album, find and tap the video that you want to play.
- 2 Tap **Movies** > **Just once**.
- 3 If the playback controls are not displayed, tap the screen to display them. To hide the controls, tap the screen again.

To pause a video

- 1 When a video is playing, tap the screen to display the controls.
- 2 Tap .

To fast forward and rewind a video

- 1 When a video is playing, tap the screen to display the controls.
- 2 Drag the progress bar marker left to rewind, or right to fast forward.

To adjust the volume of a video

- Press the volume key.

Sharing and managing photos and videos

You can share photos and videos that you've stored on your device. You can also manage them in different ways. For example, you can work with photos in batches, delete photos and link them to contacts.

- ! You might not be able to copy, send, or transfer copyright-protected items. Also, some items may not send if the file size is too large.

To share a photo or video

- 1 In Album, find and tap the photo or video that you want to share.
- 2 Tap the screen to display the toolbars, then tap .
- 3 Tap the application that you want to use to share the photo, then follow the steps to send it.

To use a photo as a contact picture

- 1 When you are viewing a photo, tap the screen to display the toolbars, then tap  > **Use as** > **Contact picture**.
- 2 If asked, select **Contacts** > **Just once**, then select a contact.

To use a photo as wallpaper

- 1 When you are viewing a photo, tap the screen to display the toolbars, then tap  > **Use as** > **Wallpaper**.
- 2 Follow the instructions on the screen.

To rotate a photo

- 1 When you are viewing a photo, tap the screen to display the toolbars, then tap .
- 2 Select **Rotate**. The photo is saved in the new orientation.

To delete a photo or video

- 1 When you are viewing a photo, tap the screen to display the toolbars, then tap .
- 2 Tap **Delete**.

To work with batches of photos or videos in Album

- 1 When viewing thumbnails of photos and videos in Album, tap , then tap **Select items**.
- 2 Tap the items that you want to work with. Selected items are indicated by a blue frame.
- 3 Use the tools in the toolbars to work with your selected items.

- 💡 To activate selection mode, you can also touch and hold an item until its frame turns blue. Then you can tap other items to select them.

Analyzing photos with faces in Album

You can analyze any photos on your device that feature people's faces. Once activated, the photo analysis feature stays on, and new photos get analyzed as they are added. After running an analysis, you can then group all photos of the same person in one folder.

To turn on the photo analysis feature

- 1 From your Home screen, tap .
- 2 Find and tap **Album**.
- 3 Drag the left edge of the Album home screen to the right, then tap **Faces**. All photos on your device get analyzed and grouped in the Unnamed faces folder.

To name a face

- 1 In the **Faces** tile, tap the **Unnamed faces** folder, then browse to the **Other faces** folder and choose the face that you want to name.
- 2 Tap **Add name**.
- 3 Type a name, then tap **Done** > **Add as new person**.

To edit a face name

- 1 When you are viewing a face in full-screen view, tap the screen to display the toolbars, then tap  > **Edit name tags**.
- 2 Tap **OK**.
- 3 Tap the name of the face that you want to edit.
- 4 Edit the name, then tap **Done** > **Add as new person**.



Editing photos with the Photo editor application

You can edit and apply effects to original photos that you've taken with your camera. For example, you can change the light effects. After you save the edited photo, the original unchanged version of the photo remains on your device.



To edit a photo

- When you are viewing a photo, tap the screen to display the toolbars, then tap .



To crop a photo

- 1 When you are viewing a photo, tap the screen to display the toolbars, then tap .
- 2 If prompted, select **Photo editor** > **Just once**.
- 3 Tap  > **Crop**.
- 4 Tap  to select an option.
- 5 To adjust the crop frame, touch and hold the edge of the crop frame. When the squares at the edges disappear, drag inward or outward to resize the frame.
- 6 To resize all sides of the crop frame at the same time, touch and hold one of the four corners to make the squares at the edges disappear, then drag the corner accordingly.
- 7 To move the crop frame to another area of the photo, touch and hold inside the frame, then drag it to the desired position.
- 8 Tap **Apply Crop**.
- 9 To save a copy of the photo as you cropped it, tap **Save**.



To apply special effects to a photo

- 1 When you are viewing a photo, tap the screen to display the toolbars, then tap .
- 2 If prompted, select **Photo editor** > **Just once**.
- 3 Tap , then select an option.
- 4 Edit the photo as desired, then tap **Save**.



To improve a photo using advanced settings

- 1 When you are viewing a photo, tap the screen to display the toolbars, then tap .
- 2 If prompted, select **Photo editor** > **Just once**.
- 3 Tap , then select an option.
- 4 To save a copy of the edited photo, tap **Save**.

To adjust the light settings for a photo

- 1 When you are viewing a photo, tap the screen to display the toolbars, then tap .
- 2 If prompted, select **Photo editor** > **Just once**.
- 3 Tap , then select an option.
- 4 To save a copy of the edited photo, tap **Save**.

To set the saturation level of colors in a photo

- 1 When you are viewing a photo, tap the screen to display the toolbars, then tap .
- 2 If prompted, select **Photo editor** > **Just once**.
- 3 Tap , then select an option.
- 4 To save a copy of the edited photo, tap **Save**.

Album homescreen menu

Through the Album homescreen menu you can browse to all your photo albums, including albums of photos and videos taken with the camera as well as content that you share online via services such as PlayMemories, Picasa™, and Facebook. Once you are logged in to such services, you can manage content, comment on photos and videos, and view comments from friends. From the Album application, you can also add geotags to photos, perform basic editing tasks, and use methods such as Bluetooth® wireless technology and email to share content.

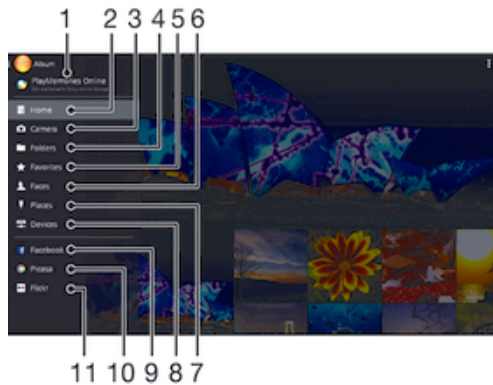

- 1 View photos and videos using the PlayMemories Online service
- 2 Return to the Album application homescreen
- 3 View all photos and videos taken with your device's camera
- 4 View all photos and videos saved to your device in different folders
- 5 View your favorite photos and videos
- 6 View all photos with faces
- 7 View your photos on a map or in globe mode
- 8 View photos and videos on the same network
- 9 View photos and videos on Facebook™
- 10 View photos and videos on Picasa™
- 11 View photos using the Flickr™ online service

! The PlayMemories Online service is not available in all countries or regions.

To view photos from online services in Album

- 1 From your Home screen, tap \llcorner .
- 2 Find and tap **Album**, then drag the left edge of the Album homescreen to the right.
- 3 Tap the desired online service, then follow the on-screen instructions to get started. All available online albums that you have uploaded to the service are displayed.
- 4 Tap any album to view its content, then tap a photo in the album.
- 5 Flick left to view the next photo or video. Flick right to view the previous photo or video.

To view and add comments to online album content

- 1 When viewing a photo from an online album, tap the screen to display the toolbars, then tap 💬 to view the comments.
- 2 Enter your comments in the input field, then tap **Post**.

To "Like" a photo or video on Facebook™

- While viewing a photo or video from one of your Facebook™ albums, tap the screen to display the toolbars, then tap 👍 to show that you "Like" the item on Facebook™.

Viewing your photos on a map

Adding location information to photos is referred to as geotagging. You can view and tag your photos on a map and show friends and family where you were when you took a particular photo. See *Adding the geographical position to your photos* on page 52 for more information.

- 💡 If you have turned on location detection and activated geotagging in the camera, you can tag your photos directly for map viewing at a later stage.



- 1 View geotagged photos in Globe view
- 2 Search a location on the map
- 3 View menu options
- 4 Double tap to zoom in. Pinch to zoom out. Drag to view different parts of the map
- 5 A group of photos and/or videos geotagged with the same location
- 6 Thumbnails of the selected group of photos and/or videos. Tap an item to view it in full screen

- 💡 If several photos were taken at the same location, only one of them appears on the map. The total number of photos appears in the top right corner, for example, 📷^9 . To view all photos in the group, tap the cover photo and then tap one of the thumbnails at the bottom of the screen.

To add a geotag to a photo

- 1 When you are viewing a photo, tap the screen to display the toolbars, then tap **Tap to set location** to open the map screen.
- 2 Find and tap the desired location to put the photo on the map.
- 3 To adjust the location of the photo, tap the location on the map where you want to move the photo to.
- 4 When you are done, tap **OK** to save the geotag and return to the photo viewer.

To view geotagged photos on a map

- 1 From your Home screen, tap ☰.
- 2 Find and tap **Album**.
- 3 Drag the left edge of the Album home screen to the right, then tap **Places**.
- 4 Tap the photo that you want to view on a map.

To view geotagged photos on a globe

- 1 From your Home screen, tap ☰.
- 2 Find and tap **Album**.
- 3 Drag the left edge of the Album homescreen to the right, then tap **Places** > 🌐.
- 4 Tap the photo that you want to view on a globe.

To change the geotag of a photo

- 1 When viewing a photo on the map in Album, touch and hold the photo until its frame turns blue, then tap the desired location on the map.
- 2 Tap **OK**.

To change the map view

- When viewing the map in Album, tap ☰, then select **Classic view** or **Satellite view**.

Videos

Watching videos in the Movies application

Use the Movies application to play movies and other video content that you've saved or downloaded to your device. The Movies application also helps you get poster art, plot summaries, genre info, and director details for each movie. You can also play your movies on other devices that are connected to the same network.

- ! Some video files may not be playable in the Movies application.



- 1 View menu options
- 2 Scroll up or down to view content
- 3 Drag the left edge of the screen to the right to browse all downloaded and saved videos
- 4 Tap to play saved or downloaded video files

- ! Sony Entertainment Network with Video Unlimited and Music Unlimited is not available in every market. Separate subscription required. Additional terms and conditions apply.

To play a video in Movies

- 1 From your Home screen, tap **⋮**, then find and tap **Movies**.
- 2 Find and tap the video that you want to play. If the video is not displayed on the screen, drag the left edge of the screen to the right to open the Movies homescreen menu, then find and tap the video that you want to play.
- 3 To display or hide the controls, tap the screen.
- 4 To pause playing, tap **⏸**. To resume playing, tap **▶**.
- 5 To rewind, drag the progress bar marker to the left. To fast forward, drag the progress bar marker to the right.

To play a video on an external device

- 1 When the video is playing, tap the screen to display all the controls.
- 2 Tap **⋮** > **Throw**.
- 3 Select an external device on which to play the video. If there is no external device available, follow the on-screen instructions to add one.

To change settings in Movies

- 1 From your Home screen, tap **⋮**, then find and tap **Movies**.
- 2 Tap **⋮** > **Settings**, then change the settings as desired.

To change the sound settings while a video is playing

- 1 While a video is playing, tap the screen to display the controls.
- 2 Tap **⋮**, then tap **Audio settings**.
- 3 Mark the checkboxes for the sound settings that you want to activate.
- 4 When you're finished, tap **OK**.

To share a video

- 1 When a video is playing, tap , then tap **Share**.
- 2 In the menu that opens, tap the application that you want to use to share the selected video, then follow the relevant steps to send it.

Transferring video content to your device

Before you start using the Movies application, it's a good idea to transfer movies, TV shows and other video content to your device from other devices, such as a computer. There are several ways to transfer your content:

- Connect your device to a computer using a USB cable and drag and drop the video files directly using the file manager application on the computer. See *Managing files using a computer* on page 90.

Managing video content

To get movie information manually

- 1 Make sure your device has an active data connection.
 - 2 From your Home screen, tap , then find and tap **Movies**.
 - 3 Drag the left edge of the screen to the right to open the Movies homescreen menu, then browse through the different categories to the video file that you want to get information on.
 - 4 Touch and hold the thumbnail for the video, then tap **Search for info**.
 - 5 In the search field, enter keywords for the video, then tap the confirm key on the keyboard. All matches are displayed in a list.
 - 6 Select a search result, then tap **Done**. The download of the information begins.
- ! You can get information about newly added videos automatically every time the Movies application opens if you mark the Get video details checkbox under Settings.
- 💡 If the downloaded information is not correct, search again using different keywords.

To clear information about a video

- 1 From your Home screen, tap , then find and tap **Movies**.
- 2 Drag the left edge of the screen to the right to open the Movies homescreen menu, then browse through the different categories and to the video file that you want to edit.
- 3 Touch and hold the video thumbnail, then tap **Clear info**.

To delete a video

- 1 From your Home screen, tap , then find and tap **Movies**.
- 2 Drag the left edge of the screen to the right to open the Movies homescreen menu, then browse through the different categories and to the video file that you want to delete.
- 3 Touch and hold the video thumbnail, then tap **Delete** from the list that appears.
- 4 Tap **Delete** again to confirm.



Video Unlimited service

Use the Video Unlimited service to rent and buy movies or TV shows that you can view not only on your Android™ device, but also on a PC, PlayStation® Portable (PSP®), PlayStation® 3 or PlayStation® Vita. Select your pick from the latest Hollywood releases, action movies, comedies, classics, and a range of other categories.

You need to create a Video Unlimited account if you want to buy or rent movies through the Video Unlimited service. If you already have a PlayStation® network account or a Sony Entertainment Network account, then you can use that account instead.

- ! If you are using a device with multiple users, you must log in as the owner, that is, the primary user, to use the Video Unlimited service.
- ! Sony Entertainment Network with Video Unlimited and Music Unlimited is not available in every market. Separate subscription required. Additional terms and conditions apply.

To get started with Video Unlimited

- 1 From your Home screen, tap :::
- 2 Find and tap .
- 3 If you are starting Video Unlimited for the first time, tap **Continue** in the Welcome screen and enter your birth date if required, then tap **Continue** again to go to the main screen of Video Unlimited.
- 4 Tap  > **Sign In**, then follow the on-screen instructions to sign in to your account, or create a new account, to buy or rent movies.

Connectivity

Mirroring the screen of your device on a TV using a cable

You can connect your device to a TV set using an MHL cable or an HDMI cable to view content saved in your device on the TV screen. When you connect your device in this way to a compatible TV set, the TV launcher application opens. This application helps you to play media files from your device on TVs and other devices.

- 💡 You may have to purchase a cable and an adaptor separately.

To view content from your device on a TV which supports MHL input

- 1 Connect your device to the TV using an MHL cable. **MHL** appears in your device's status bar after a connection is established.
- 2 The **TV launcher** application starts automatically. Follow the instructions to view your media files on the TV.

To view content from your device on a TV which supports HDMI™ input

- 1 Connect your device to an MHL adaptor and connect the adaptor to a USB power supply.
- 2 Connect the adaptor to a TV using a HDMI™ cable. **MHL** appears in your device's status bar after a connection is established.
- 3 The **TV launcher** application starts automatically. Follow the instructions to view your media files on the TV.

To view help about using the TV remote control

- 1 While your device is connected to the TV set, drag the status bar downward to open the Notification panel.
 - 2 Tap **MHL connected**.
- 💡 You can also press the yellow button on the TV remote control to open the Notification panel.

To disconnect your device from the TV set

- Disconnect the MHL™ cable or the MHL adaptor from your device.

Mirroring the screen of another Xperia™ device wirelessly on your device

You can use the Screen mirroring feature to share the screen of another Xperia™ device on the screen of your device without using a cable connection. Wi-Fi Direct™ technology creates a wireless connection between the two devices. The other Xperia™ device, for example, an Xperia™ phone or tablet, must support Wi-Fi CERTIFIED Miracast™.

To mirror the screen of the Xperia™ device on your device

- 1 **Your device:** From your Home screen, tap **:::**.
- 2 Find and tap **Settings > Xperia™ Connectivity > Screen mirroring > OK**.
- 3 Tap **Standby mode**.
- 4 **Other device:** From your Home screen, tap **:::**.
- 5 Find and tap **Settings > Xperia™ Connectivity > Screen mirroring > Turn on Screen mirroring**.
- 6 Tap **OK** and select a device.
- 7 **Your device:** Tap **Accept** to connect with your device.

Mirroring the screen of your device wirelessly on a TV

You can use the Screen mirroring feature to show the screen of your device on a TV or other large display without using a cable connection. Wi-Fi Direct™ technology creates a wireless connection between the two devices, so you can sit back and enjoy your

favorite photos from the comfort of your couch. You can also use this feature to listen to music from your device via the TV's speakers.

- ! Your TV must support screen mirroring based on Wi-Fi CERTIFIED Miracast™ for the functionality described above to work. If your TV does not support screen mirroring, you may need to purchase a wireless display adapter separately.
- ! When using screen mirroring, the image quality may sometimes be negatively impacted if there is interference from other Wi-Fi® networks.

To mirror the screen of your device on a TV screen

- 1 **TV:** Follow the instructions in the User guide for your TV to turn on the screen mirroring function.
- 2 **Your device:** From your Home screen, tap :::.
- 3 Find and tap **Settings > Xperia™ Connectivity > Screen mirroring**.
- 4 Tap **Turn on Screen mirroring** and select the device you want to mirror content to.

- ! When using screen mirroring, do not cover the Wi-Fi antenna area of your device.
- ! Your TV must support screen mirroring based on Wi-Fi CERTIFIED Miracast™ for the functionality described above to work.

Sharing content with DLNA Certified™ devices

You can view or play media content saved to your device on other devices such as, for example, a TV, or a computer. Such devices must be DLNA Certified™ by the Digital Living Network Alliance and all devices must be connected to the same Wi-Fi® network in order for content to be shared. You can also view or play content from other DLNA Certified™ devices on your device.

After you set up the sharing of content between devices, you can, for example, listen to music files stored on your home computer from your device, or view photos taken with your device's camera on a large-screen TV.

Playing files from DLNA Certified™ devices on your device

When you play files from another DLNA Certified™ device on your device, this other device acts as a server. In other words, it shares content over a network. The server device must have its content sharing function enabled and give access permission to your device. It also must be connected to the same Wi-Fi® network as your device.

To play a shared track on your device

- 1 Make sure the devices that you want to share files with are connected to the same Wi-Fi® network as your device.
- 2 From your Home screen, tap :::, then find and tap **WALKMAN**.
- 3 Select a device from the list of connected devices.
- 4 Browse the folders of the connected device and select the track that you want to play. The track starts playing automatically.

To play a shared video on your device

- 1 Make sure the devices that you want to share files with are connected to the same Wi-Fi® network as your device.
- 2 From your Home screen, tap :::, then find and tap **Movies**.
- 3 Select a device from the list of connected devices.
- 4 Browse the folders of the connected device and select the video that you want to play.



To view a shared photo on your device

- 1 Make sure the devices that you want to share files with are connected to the same Wi-Fi® network as your device.
- 2 From your Home screen, tap ☰.
- 3 Find and tap **Album** > **My albums**. All your available online albums and connected devices are displayed.
- 4 Select a device from the list of connected devices.
- 5 Browse the folders of the connected device and select a photo to view it.



Playing files from your device on DLNA Certified™ devices

Before you can view or play media files from your device on other DLNA Certified™ devices, you must set up file sharing on your device. The devices that you share content with are called client devices. For example, a TV, computer or tablet can act as client devices. Your device works as a media server when it makes content available to client devices. When you set up file sharing on your device, you must also give access permission to client devices. After you do so, such devices appear as registered devices. Devices that are waiting for access permission are listed as pending devices.



To set up file sharing with other DLNA Certified™ devices

- 1 Connect your device to a Wi-Fi® network.
 - 2 From your Home screen, tap ☰, then find and tap .
 - 3 Tap , then tap **Media server**.
 - 4 To turn on the **Share media** function, drag the slider.  appears in the status bar. Your device can now work as a media server.
 - 5 Connect your computer or other devices to the same Wi-Fi® network as your device.
 - 6 A notification appears in the status bar of your device. Open the notification and set the relevant access permissions for other devices.
- ! The instructions described above may differ depending on the client devices used. Refer to your client device User guide for more information. If the device cannot connect, check that your Wi-Fi® network is working.
- 💡 You can also access the Media server menu under Settings > Xperia™ Connectivity > Media server settings. If you close the Media server view, the file sharing function stays running in the background.



To stop sharing files with other DLNA Certified™ devices

- 1 From your Home screen, tap ☰, then find and tap .
- 2 Tap , then tap **Media server**.
- 3 Drag the slider to turn off the **Share media** function.



To set access permissions for a pending device

- 1 From your Home screen, tap ☰, then find and tap .
- 2 Tap , then tap **Media server**.
- 3 Select a device from the **Pending devices** list.
- 4 Select an access permission level.





To change the name of a registered device

- 1 From your Home screen, tap ☰, then find and tap .
- 2 Tap , then tap **Media server**.
- 3 Select a device from the **Registered devices** list, then select **Change name**.
- 4 Enter a new name for the device.

To change the access level of a registered device

- 1 From your Home screen, tap ☰, then find and tap .
- 2 Tap , then tap **Media server**.
- 3 Select a device from the **Registered devices** list.
- 4 Tap **Change access level** and select an option.

To get help about sharing content with other DLNA Certified™ devices





- 1 From your Home screen, tap , then find and tap .
- 2 Tap , then tap **Media server**.
- 3 Tap .

Playing files on a Digital Media Renderer device



Using DLNA™ technology, you can push media content saved on your device to another device connected to the same Wi-Fi® network. The other device must be able to function as a Digital Media Renderer (DMR) device, which means that it can render, or play, content received from your device. A DMR device can be, for example, a TV with DLNA function, or a PC running Windows® 7 or higher.

- ! The settings for enabling the Digital Media Renderer may vary depending on the device used. Refer to the user guide for the respective device for more detailed information.
- ! Content with Digital Rights Management (DRM) cannot be played on a Digital Media Renderer device using DLNA™ technology.

To view photos or videos from your device on a DMR device

- 1 Ensure you have correctly set up the DMR device and that it is connected to the same Wi-Fi® network as your device.
 - 2 From your Home screen, tap .
 - 3 Find and tap **Album**.
 - 4 Browse to and open the file that you want to view.
 - 5 Tap the screen to display the toolbars, then tap  and select a DMR device to share your content with. The selected files start playing in chronological order on the device that you select.
 - 6 To disconnect from the DMR device, tap  and select your device. The file stops playing on the DMR device but continues playing on your device.
- 💡 You can also share a video from the Movies application on your device by tapping the video and then tapping .

To play a music track from your device on a DMR device

- 1 Make sure that you have correctly set up the DMR device and that it is connected to the same Wi-Fi® network as your device.
- 2 From your Home screen, tap , then find and tap **WALKMAN**.
- 3 Select a music category and browse to the track that you want to share, then tap the track.
- 4 Tap  and select a DMR device to share your content with. The track plays automatically on the device that you select.
- 5 To disconnect from the DMR device, tap  and select your device. The track stops playing on the DMR device but continues playing on your device.

Playing games on a TV using a DUALSHOCK™3 wireless controller

You can play PlayStation® Mobile games stored on your device on a TV and control the games using a DUALSHOCK™3 wireless controller. First, you need to establish a wireless connection between the DUALSHOCK™3 wireless controller and your device, then you can connect your device to the TV using a cable.

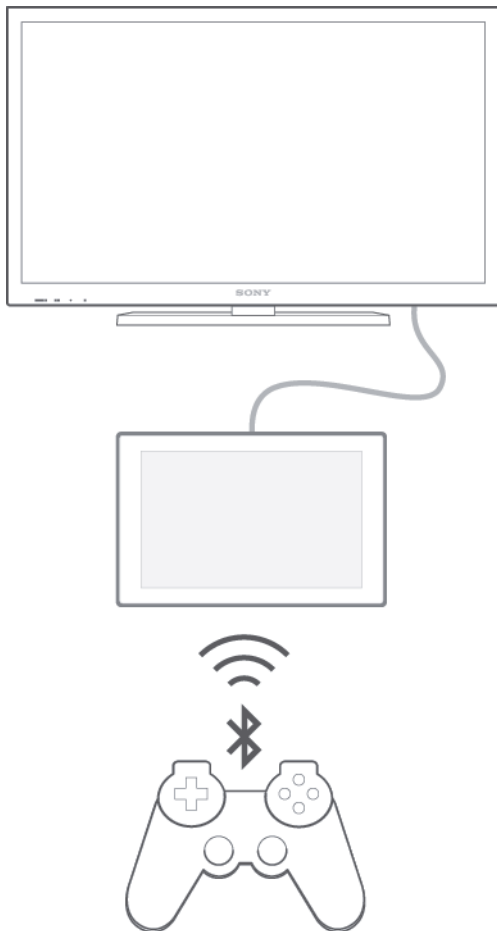

- 💡 To set up a connection between a DUALSHOCK™3 wireless controller and your device, a USB On-The-Go adapter is required.

To set up a connection with a DUALSHOCK™3 wireless controller

- 1 Make sure the Bluetooth® function on your device is turned on.
- 2 Connect a USB On-The-Go (OTG) adaptor to your device.
- 3 Connect the DUALSHOCK™3 wireless controller to the OTG adaptor using a USB cable
- 4 When **Controller connected(wired)** appears in the status bar at the top of your device screen, unplug the USB cable.
- 5 When **Controller connected(wireless)** appears in the status bar, a wireless connection is established.

NFC

Use Near Field Communications (NFC) to share data with other devices, such as a video, photo, web page address, music file, or contact. You can also use NFC to scan tags that give you more information about a product or service as well as tags that activate certain functions on your device.



NFC is a wireless technology with a maximum range of one centimeter, so the devices sharing data must be held close to each other. Before you can use NFC, you must first turn on the NFC function, and the screen of your device must be active.

- ! NFC may not be available in all countries and/or regions.



To turn on the NFC function

- 1 From your Home screen, tap ⋮.
- 2 Find and tap **Settings > More....**
- 3 Mark the **NFC** checkbox.

To share a contact with another device using NFC

- 1 Make sure that both devices have the NFC function turned on, and that both screens are active.
 - 2 To view contacts, go to your Home screen, tap :::, then tap .
 - 3 Tap the contact that you want to share.
 - 4 Hold your device and the receiving device back to back so that the NFC detection areas of each device touch each other. When the devices connect, a thumbnail of the contact appears.
 - 5 Tap the thumbnail to start the transfer.
 - 6 When the transfer is done, the contact information is displayed on the screen of the receiving device and is also saved on the receiving device.
-  The front part of your device that corresponds to the NFC detection area (at the back) is also NFC enabled. So you can also touch this part of your device to other devices during NFC transactions.

To share a music file with another device using NFC

- 1 Make sure that both your device and the receiving device have the NFC function turned on, and that both screens are active.
 - 2 To open the Walkman® application, tap :::, then find and tap .
 - 3 Select a music category and browse to the track you want to share.
 - 4 Tap the track to play it. You can then tap  to pause the track. The transfer works whether the track is playing or paused.
 - 5 Hold your device and the receiving device back to back so that the NFC detection areas of each device touch each other. When the devices connect, a thumbnail of the track appears.
 - 6 Tap the thumbnail to start the transfer.
 - 7 When the transfer is done, the music file plays immediately on the receiving device. At the same time, the file is saved on the receiving device.
-  The front part of your device that corresponds to the NFC detection area (at the back) is also NFC enabled. So you can also touch this part of your device to other devices during NFC transactions.

To share a photo or video with another device using NFC

- 1 Make sure that both devices have the NFC function turned on, and that both screens are active.
 - 2 To view photos and videos in your device, go to your Home screen, tap :::, then find and tap **Album**.
 - 3 Tap the photo or video that you want to share.
 - 4 Hold your device and the receiving device back to back so that the NFC detection areas of each device touch each other. When the devices connect, a thumbnail of the track appears.
 - 5 Tap the thumbnail to start the transfer.
 - 6 When the transfer is done, the photo or video is displayed on the screen of the receiving device. At the same time, the item is saved on the receiving device.
-  The front part of your device that corresponds to the NFC detection area (at the back) is also NFC enabled. So you can also touch this part of your device to other devices during NFC transactions.

To share a web address with another device using NFC

- 1 Make sure that both devices have the NFC function turned on, and that both screens are active.
 - 2 From your Home screen, tap :::.
 - 3 To open the web browser, find and tap .
 - 4 Load the web page that you want to share.
 - 5 Hold your device and the receiving device back to back so that the NFC detection areas of each device touch each other. When the devices connect, a thumbnail of the track appears.
 - 6 Tap the thumbnail to start the transfer.
 - 7 When the transfer is done, the web page is displayed on the screen of the receiving device.
- 💡 The front part of your device that corresponds to the NFC detection area (at the back) is also NFC enabled. So you can also touch this part of your device to other devices during NFC transactions.

Scanning NFC tags

Your device can scan various kinds of NFC tags. For example, it can scan embedded tags on a poster, on a billboard advertisement, or beside a product in a retail store. You can receive additional information, such as a web address.

To scan an NFC tag

- 1 Make sure that your device has the NFC function turned on and that the screen is active.
- 2 Place your device over the tag so that the NFC detection area touches it. Your device scans the tag and displays the content collected. Tap the content of the tag to open it.
- 3 To open the tag, tap it.

Connecting to an NFC compatible device

You can connect your device to other NFC compatible devices produced by Sony, such as a speaker or a headphone. When establishing this kind of connection, refer to the User guide of the compatible device for more information.

- ! You may need to have Wi-Fi® or Bluetooth® activated on both devices for the connection to work.

To share your mobile connection by NFC Wi-Fi® tethering

- 1 Make sure that both devices have the NFC function turned on, and that both screens are active.
- 2 From your Home screen, tap :::.
- 3 Find and tap **Settings > More... > Tethering & Mobile Hotspot > NFC Wi-Fi tethering**.
- 4 Tap **OK** if prompted.
- 5 Hold devices back to back so that the NFC detection areas of each device touch each other, and they will connect automatically.

- ! This function only works with devices that also support NFC Wi-Fi tethering.

Bluetooth® wireless technology

Use the Bluetooth® function to send files to other Bluetooth®-compatible devices, or to connect to hands-free accessories. Bluetooth® connections work better within 33 feet (10 meters), with no solid objects in between. In some cases you have to manually pair your device with other Bluetooth® devices.

- ! Interoperability and compatibility among Bluetooth® devices can vary.
- ! If you are using a device with multiple users, each user can change the Bluetooth® settings, and the changes affect all users.

To turn on the Bluetooth® function and make your device visible

- 1 From your Home screen, tap ☰.
- 2 Find and tap **Settings**.
- 3 Tap the on-off switch beside **Bluetooth** so the Bluetooth® function is turned on.
- 4 Tap **Bluetooth**. Your device and a list of available Bluetooth® devices appear.
- 5 Tap your device name to make your device visible to other Bluetooth® devices.

To adjust your device's visibility time to other Bluetooth® devices

- 1 From your Home screen, tap ☰.
- 2 Find and tap **Settings > Bluetooth**.
- 3 Press  and select **Visibility timeout**.
- 4 Select an option.

Naming your device

You can give your device a name. This name is shown to other devices after you have turned on the Bluetooth® function and your device is set to visible.

To give your device a name

- 1 Make sure that the Bluetooth® function is turned on.
- 2 From your Home screen, tap ☰.
- 3 Find and tap **Settings > Bluetooth**.
- 4 Tap  and select **Rename tablet**.
- 5 Enter a name for your device.
- 6 Tap **Rename**.

Pairing with another Bluetooth® device

When you pair your device with another device, you can, for example, connect your device to a Bluetooth® headset or a Bluetooth® car kit and use these other devices to share music.

Once you pair your device with another Bluetooth® device, your device remembers this pairing. When pairing your device with a Bluetooth® device, you may need to enter a passcode. Your device will automatically try the generic passcode 0000. If this does not work, refer to the user guide for your Bluetooth® device to get the device passcode. You do not need to re-enter the passcode the next time you connect to a previously paired Bluetooth® device.

- ! Some Bluetooth® devices, for example, most Bluetooth® headsets, require you to both pair and connect with the other device.
- ! You can pair your device with several Bluetooth® devices, but you can only connect to one Bluetooth® profile at the same time.

To pair your device with another Bluetooth® device

- 1 Make sure the device you want to pair with has the Bluetooth® function activated and is visible to other Bluetooth® devices.
- 2 From your device's Home screen, tap ☰.
- 3 Find and tap **Settings > Bluetooth**. All available Bluetooth® devices appear in a list.
- 4 Tap the Bluetooth® device you want to pair with.
- 5 Enter a passcode, if required, or confirm the same passcode on both devices. Your device and the other device are now paired.

To connect your device to another Bluetooth® device

- 1 From your Home screen, tap ⋮.
- 2 Find and tap **Settings** > **Bluetooth**.
- 3 Tap the Bluetooth® device you want to connect to.

To unpair a Bluetooth® device

- 1 From your Home screen, tap ⋮.
- 2 Find and tap **Settings** > **Bluetooth**.
- 3 Under **Paired devices**, tap ✕ beside the name of the device you want to unpair.
- 4 Tap **Unpair**.

Sending and receiving items using Bluetooth® technology

Share items with other Bluetooth® compatible devices such as phones or computers.

You can send and receive several kinds of items using the Bluetooth® function, such as:

- Photos and videos
- Music and other audio files
- Contacts
- Web pages

To send items using Bluetooth®

- 1 **Receiving device:** Make sure the Bluetooth® function is turned on and that the device is visible to other Bluetooth® devices.
- 2 **Sending device:** Open the application which contains the item that you want to send, and scroll to the item.
- 3 Depending on the application and on the item that you want to send, you may need to, for example, touch and hold the item, open the item, and press . Other ways to send an item may exist.
- 4 Select **Bluetooth**.
- 5 Turn on Bluetooth® if you are asked to do so.
- 6 Tap the name of the receiving device.
- 7 **Receiving device:** If asked, accept the connection.
- 8 **Sending device:** If asked, confirm the transfer to the receiving device.
- 9 **Receiving device:** Accept the incoming item.

To receive items using Bluetooth®

- 1 Make sure that the Bluetooth® function is on and is visible to other Bluetooth® devices.
- 2 The sending device now starts sending data to your device.
- 3 If prompted, enter the same passcode on both devices, or confirm the suggested passcode.
- 4 When you are notified of an incoming file to your device, drag the status bar downward and tap the notification to accept the file transfer.
- 5 Tap **Accept** to start the file transfer.
- 6 To view the progress of the transfer, drag the status bar downward.
- 7 To open a received item, drag the status bar downward and tap the relevant notification.

To view files you have received using Bluetooth®

- 1 From your Home screen, tap ⋮.
- 2 Find and tap **Settings** > **Bluetooth**.
- 3 Press  and select **Show received files**.

One-touch setup

You can use the One-touch setup function to automatically launch the setup of several features that work wirelessly between two Xperia™ devices. For example, you can use

One-touch setup to launch the configuration of basic settings for Screen mirroring and Xperia Link™.

The One-touch setup function is activated using NFC. Other one-touch features include Bluetooth® and Media Server. For more information about the setup of Screen mirroring, Media Server, NFC and Bluetooth®, refer to the relevant sections of the User guide.

To start One-touch setup on your device

- 1 From your Home screen, tap ☰.
 - 2 Find and tap **Settings > Xperia™ Connectivity > One-touch setup**. The NFC function is automatically turned on.
 - 3 Make sure the NFC function on the other Xperia™ device is turned on.
 - 4 Make sure the screens of both devices are unlocked and active.
 - 5 Hold the two devices together so that the NFC detection area of each device touches the other. The One-touch setup function launches automatically.
- ! Both devices must support the One-touch setup function.

Using your device as a fitness hub with ANT+™

You can use your device with health and fitness products that also support ANT+™ technology. For example, if you go running with an ANT+™ compatible heart rate monitor and a foot pod (to measure pace and distance), you can collect all the data from the run on your device. You can then analyze your performance and see how you can improve.

You can download a range of applications from Google Play™ that support ANT+™ sport, fitness, and health devices. For information about ANT+™ compatible products, go to www.thisisant.com/directory.

Travel and maps

Using location services

Location services allow applications such as Maps and the camera to use information from Wi-Fi® networks as well as Global Positioning System (GPS) information to determine your approximate location. If you're not within a clear line of sight to GPS satellites, your device can determine your location using the Wi-Fi® function.

In order to use your device to find out where you are, you need to enable location services.

To enable location services

- 1 From your Home screen, tap **⋮**.
- 2 Find and tap **Settings > Location**.
- 3 Drag the slider beside **Location** to the right.
- 4 Tap **Agree** twice to confirm.

! When you enable location services, both GPS satellites and Google's location service get enabled by default. You can disable either option manually.

To allow Google apps to access your location

- 1 From your Home screen, tap **⋮**.
- 2 Find and tap **Settings > Google > Location**.
- 3 Drag the slider beside **Location** to the right.
- 4 Tap **Agree** twice to confirm.

! When you enable location services, both GPS satellites and Google's location service get enabled by default. You can disable either option manually.

Improving GPS accuracy

The first time you use the GPS function in your device, it can take 5 to 10 minutes for your location to be found. To help the search, make sure you have a clear view of the sky. Stand still and don't cover the GPS antenna (the highlighted area in the image). GPS signals can pass through clouds and plastic, but not through most solid objects such as buildings and mountains. If your location isn't found after a few minutes, move to another location.

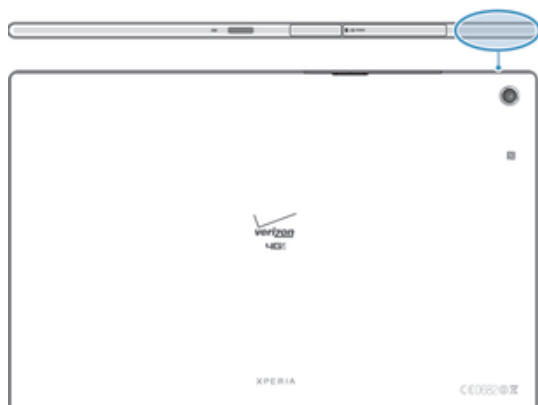

Google Maps™ and navigation

Use Google Maps™ to track your current location, view real-time traffic situations and receive detailed directions to your destination.

When you view a map, you use data traffic to get an Internet connection, and data is transferred to your device. So it's a good idea to save a map and make it available offline before you take a trip. This way, you can avoid high roaming costs.

- ! The Google Maps™ application requires the use of an Internet connection when used online. You may incur data connection charges when you connect to the Internet from your device. Contact your network operator for more information. The Google Maps™ application may not be available in every market, country, or region.



- 1 View help and options.
- 2 Enter an address or name to search for a location, for example, a restaurant's name or address.
- 3 Select a transportation mode and get directions to your destination.
- 4 View your account profile.
- 5 Location mark – shows a searched location on the map.
- 6 Show your current location.

To show your location on the map

- 1 From your Home screen, tap ☰.
- 2 Find and tap **Maps**, then tap 📍.

To search for a location

- 1 From your Home screen, tap ☰.
- 2 Find and tap **Maps**.
- 3 In the search field, enter the name of the location you want to find.
- 4 Tap the Enter key on the keyboard to start the search, or select a suggested location from the list. If the search is successful, the location is indicated by 📍 on the map.

To get directions

- 1 While viewing a map, tap 📍.
- 2 Select a transportation mode, then enter your starting point and your destination. The recommended routes appear in a list.
- 3 Tap an option from the list of recommended routes to view the directions on a map.

To make a map available offline

- 1 While viewing a map, tap the search field.
- 2 Scroll to the bottom and tap **Make this map area available offline**. The area shown on the map gets saved to your device.

To learn more about Google Maps™

- When you use Google Maps™, tap ☰, then tap **Help**.

Using your device with a car infotainment system

Connect your device to a MirrorLink™ certified car infotainment system using a USB cable to, for example, use a navigation app or play music from your device while driving. The car infotainment system mirrors all features on your device and gives you access to all applications. When connected, you can navigate the apps using the car infotainment system controls.

- ! Some applications may not be available in driving mode. Also, protected data, such as videos that are strictly protected under Digital Rights Management (DRM), is not made available via MirrorLink™.



To connect your device to a car infotainment system

- Connect your device and the car infotainment system using a USB cable. The screen of your device appears on the screen of the infotainment system.
- ! You may need to start MirrorLink™ manually if the connection between your device and the infotainment system is not established automatically.

To start MirrorLink™ manually

- 1 Make sure that your device is connected to the car infotainment system using a USB cable.
- 2 From your Home screen, tap ⋮.
- 3 Find and tap **Settings > Xperia™ Connectivity > Start MirrorLink™**.
- 4 Tap **OK**.

Airplane mode

In Airplane mode, the network and radio transceivers are turned off to prevent disturbance to sensitive equipment. However, you can still play games, listen to music, watch videos and other content, as long as all this content is saved on your memory card or internal storage. You can also be notified by alarms, if alarms are activated.

- 💡 Turning on Airplane mode reduces battery consumption.

To turn on Airplane mode

- 1 From your Home screen, tap ⋮.
- 2 Find and tap **Settings**.
- 3 Drag the slider beside **Airplane mode** to the right to turn on the **Airplane mode** function.

- 💡 You can also press and hold down the power key (⏻) and then select Airplane mode in the menu that opens.

Calendar and alarm clock

Calendar

Use the Calendar application to manage your time schedule. If you have signed into and synchronized your device with one or several online accounts that include calendars, for example, your Google™ account or Xperia™ with Facebook account, then calendar events from these accounts will also appear in the Calendar application. You can select which calendars you want to integrate into the combined Calendar view.

When an appointment time approaches, your device plays a notification sound to remind you. Also,  appears in the status bar.



- 1 Select a view type and the calendars that you want to view
- 2 Add a calendar event
- 3 Search for events
- 4 Return to the current date
- 5 Access settings and other options
- 6 Agenda for the selected day
- 7 Flick left or right to browse more quickly

To create a calendar event

- 1 From your Home screen, tap , then tap **Calendar**.
- 2 Tap **+New event**.
- 3 If you have synchronized your calendar with one or more accounts, select the account to which you want to add this event. If you only want to add this event on your device, tap **Device calendar**.
- 4 Enter or select the desired information and add attendees to the event.
- 5 To save the event and send out invitations, tap **Done**.

To view a calendar event

- 1 From your Home screen, tap , then tap **Calendar**.
- 2 Tap the event you want to view.

To view multiple calendars

- 1 From your Home screen, tap , then find and tap **Calendar**.
- 2 Tap , then mark the checkboxes for the calendars you want to view.

To zoom the calendar view

- When the **Week** or the **Day** view is selected, pinch the screen to zoom in.

To display national holidays in the Calendar application

- 1 From your Home screen, tap **Calendar**.
- 2 Tap **Settings**, then tap **Calendar view settings**.
- 3 Tap **National holidays**.
- 4 Select an option, or a combination of options, then tap **OK**.

To display birthdays the in Calendar application

- 1 From your Home screen, tap **Calendar**.
- 2 Tap **Settings**, then tap **Calendar view settings**.
- 3 Drag the slider beside **Birthdays** to the right.
- 4 Tap **Birthdays**, then select the contact group for which you want to display birthdays.

To display weather forecasts in the Calendar application

- 1 From your Home screen, tap **Calendar**.
- 2 Tap **Settings**, then tap **Calendar view settings**.
- 3 Drag the slider beside **Weather forecast** to the right.
- 4 If location services are disabled, tap **Add**, then search for the city that you want to add.

For more information about how to enable location services, see *Using location services* on page 79.

To change weather forecast settings in the Calendar application

- 1 From your Home screen, tap **Calendar**.
- 2 Tap **Settings**, then tap **Calendar view settings**.
- 3 Tap **Weather forecast**.
- 4 Adjust the settings as desired.

Alarm and clock

You can set one or several alarms and use any sound saved on your device as the alarm signal. The alarm does not sound if your device is turned off. But it does sound when the device is set to silent mode.

The alarm time format displayed is the same as the format you select for your general time settings, for example, 12-hour or 24-hour.



- 1 Access the alarm home screen
- 2 View a world clock and adjust settings
- 3 Access the stopwatch function
- 4 Access the timer function
- 5 Add a new alarm
- 6 View options
- 7 Turn an alarm on or off

To set a new alarm

- 1 From your Home screen, tap .
- 2 Find and tap **Alarm & clock**.
- 3 Tap **+**.
- 4 Tap **Time** and adjust the time by scrolling up and down.
- 5 Tap **Set**.
- 6 If desired, edit other alarm settings.
- 7 Tap **Done**.

To snooze an alarm when it sounds

- Tap **Snooze**.

To turn off an alarm when it sounds

- Drag  to the right.
-  To turn off a snoozed alarm, you can drag down the status bar to open the Notification panel and then tap .

To edit an existing alarm

- 1 Open the Alarm & clock application, then tap the alarm you want to edit.
- 2 Make the desired changes.
- 3 Tap **Done**.

To turn an alarm on or off

- Open the Alarm & clock application, then drag the slider next to the alarm to the on or off position.

To delete an alarm

- 1 Open the Alarm & clock application, then touch and hold the alarm that you want to delete.
- 2 Tap **Delete alarm**, then tap **Yes**.

To set the sound for an alarm

- 1 Open the Alarm & clock application, then tap the alarm you want to edit.
- 2 Tap **Alarm sound** and select an option, or tap  to select from your music files.
- 3 Tap **Done** twice.

To set a recurring alarm

- 1 Open the Alarm & clock application, then tap the alarm you want to edit.
- 2 Tap **Repeat**.
- 3 Mark the checkboxes for the desired days, then tap **OK**.
- 4 Tap **Done**.

To activate the vibrate function for an alarm

- 1 Open the Alarm & clock application, then tap the alarm you want to edit.
- 2 Mark the **Vibrate** checkbox.
- 3 Tap **Done**.

To set alarms to sound when the device is in silent mode



- 1 Open the Alarm & clock application, then tap the alarm you want to edit.
- 2 Mark the **Alarm in silent mode** checkbox, then tap **Done**.

Support and maintenance

Help for your device

Use the Help application in your device to read Get started guide and User guide, get to know icon glossary, view your usage and customize your features of Verizon mobile, and watch help videos and other product-related information.

To access the Help application

- 1 From your Home screen, tap .
 - 2 Find and tap , then select the required help item.
- ! Make sure that you have a working Internet connection, preferably over Wi-Fi®, to limit data traffic charges when using the Help application.

Help in menus and applications

Some applications and settings have help available in the options menu, which is normally indicated by  in the specific applications.

Help us improve our software

You can enable the sending of usage info from your device so that Sony Mobile can receive anonymous bug reports and statistics that help improve our software. None of the information gathered includes personal data.

To allow the sending of usage info

- 1 From your Home screen, tap .
- 2 Find and tap **Settings** > **About tablet** > **Usage info settings**.
- 3 Mark the **Send usage info** checkbox if it is not already marked.
- 4 Tap **Agree**.

Media Formats

Audio Playback	Decoder format	Supported in file format
	AAC (AAC-LC, AAC+, eAAC+, AAC-ELD)	3GPP (.3gp, 3gpp), MP4 (.mp4, .m4a), ADTS (.aac)
	AMR-NB, AMR-WB	3GPP (.3gp, .3gpp), MP4 (.mp4, .m4a), AMR (.amr, .awb)
	FLAC	FLAC (.flac), Matroska (.mka)
	MIDI	SMF (.mid), XMF (.xmf), Mobile XMF (.mxmf), OTA (.ota), RTTTL (.rtttl), RTX (.rtx), iMelody (imy)
	MP3	MP3 (.mp3)
	PCM	WAV (.wav)
	Vorbis	OGG (.ogg), Matroska (.mkv)
	WMA	ASF (.wma)
Audio Recording	Encoder format	Supported in file format
	AAC (AAC-LC, AAC+, AAC-ELD)	3GPP (.3gp, .3gpp), MP4 (.mp4, .m4a)
	AMR (AMR-NB, AMR-WB)	3GPP (.3gp, .3gpp), MP4 (.mp4, .m4a), AMR (.amr)

Image Playback	Decoder format	Supported in file format
	BMP	BMP (.bmp)
	GIF	GIF (.gif)
	JPEG	JPEG (.jpg, .jpeg)
	PNG	PNG (.png)
	WebP	WebP (.webp)
	Windows bitmap	BMP (.bmp)
Image Capture	Encoder format	Supported in file format
	JPEG	JPEG (.jpg)
Video Playback	Decoder format	Supported in file format
	MPEG-4	3GPP (.3gp, .3gpp), MP4 (.mp4, .m4v), Matroska (.mkv), AVI (.avi), Xvid (.xvid)
	H.263	3GPP (.3gp, .3gpp), MP4 (.mp4, .m4v)
	H.26	3GPP (.3gp, .3gpp), MP4 (.mp4, .m4v), Matroska (.mkv)
	H.265*	MP4 (.mp4, .m4v)
	VP8	WebM (.webm), Matroska (.mkv)
	VP9	WebM (.webm)
Video Recording	Encoder format	Supported in file format
	MPEG-4	3GPP (.3gp), MP4 (.mp4)
	H.263	3GPP (.3gp), MP4 (.mp4)
	H.264	3GPP (.3gp), MP4 (.mp4)
Audio/Video Streaming	Streaming transport	HLS HTTP progressive streaming MPEG-DASH RTSP
DRM	DRM (Digital Rights Management) – features the rights and copy protection of downloaded content	OMA DRM v1.0 Marlin DRM Widevine Level 3 PlayReady DRM (available in specific regions)

Finding a lost device



If you have a Google™ account, the my Xperia web service can help you locate and secure your device if you ever lose it. You can:

- Locate your device on a map.
 - Sound an alert, even if the device is in silent mode.
 - Remotely lock the device and make the device display your contact information to anyone who finds it.
 - As a last resort, remotely clear the internal and external memory of the device.
- ! The my Xperia service may not be available in all countries/regions.

To activate the my Xperia service

- 1 From your Home screen, tap \llbracket .
 - 2 Find and tap **Settings** > **Security** > **my Xperia** > **Activate**.
 - 3 Mark the checkbox, then tap **Accept**.
- ! To verify that the my Xperia service can locate your device, go to myxperia.sonymobile.com and sign in using the same Google™ account that you have set up on your device.

IMEI number

Every device has a unique IMEI (International Mobile Equipment Identity) number. You should keep a copy of this number. If your device is stolen, your network provider can use your IMEI number to stop the device from accessing the network in your country.

To view your IMEI number

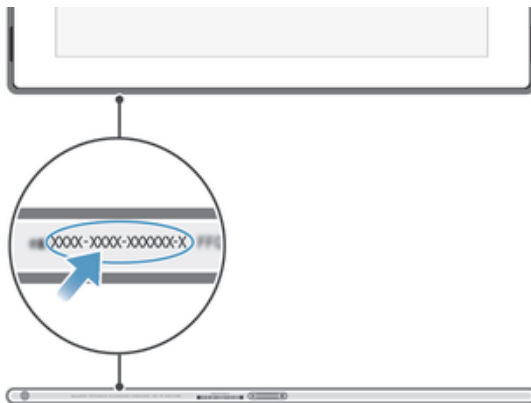

Battery and power management

Your device has an embedded battery. You can keep track of your battery consumption and see which applications are using the most power. You can also view an estimate of how much time is left before your battery runs out. The estimated battery time is based on your most recent usage pattern.

To make the battery last longer, you can use one or more battery-saving modes, which include STAMINA mode, Low battery mode, and Queue background data mode. Each

mode works in a different way and controls several power-consuming functions on your device.

To view which applications use the most battery power

- 1 From your Home screen, tap ☰.
- 2 Find and tap **Settings > Battery > Battery usage**.

To view the estimated battery time

- 1 From your Home screen, tap ☰.
- 2 Find and tap **Settings > Battery**.

Improving battery time using STAMINA mode

Use STAMINA mode to automatically improve battery time when the battery reaches a certain charge level. A function called Extended standby recognizes when your screen is not active and can automatically disable Wi-Fi® and cellular data. Most applications then become inactive. Once the screen becomes active again, your device starts to function normally and all disabled functions resume. You can exclude some applications and services from being paused in STAMINA mode.

STAMINA mode also has a feature that restricts hardware performance while you are using your device, to save even more power. When this feature is activated, your device can still function normally.

- ! If you are using a device with multiple users, you may need to log in as the owner, that is, the primary user, to activate or deactivate the STAMINA mode feature.

To activate STAMINA mode

- 1 From your Home screen, tap ☰.
- 2 Find and tap **Settings > Battery**.
- 3 Drag the slider beside **STAMINA mode** to the right.
- 4 If prompted, tap **Turn on**.  appears in the status bar once the battery reaches a set level.

- ! If you are activating STAMINA mode for the first time, the Extended standby checkbox is marked by default.

To choose when to activate STAMINA mode

- 1 From your Home screen, tap ☰.
- 2 Find and tap **Settings > Battery > STAMINA mode > Activation**.
- 3 Drag the slider to adjust the battery level at which you want to activate STAMINA mode.
- 4 Tap **OK**.

- 💡  appears in the status bar when the battery reaches the level that you set.

To activate the Extended standby function

- 1 From your Home screen, tap ☰.
- 2 Find and tap **Settings > Battery**, then tap **STAMINA mode**.
- 3 Mark the **Extended standby** checkbox if it is not already marked, then tap **Turn on**, if prompted.

To select which applications to run in STAMINA mode

- 1 From your Home screen, tap ☰.
- 2 Find and tap **Settings > Battery**, then tap **STAMINA mode**.
- 3 Make sure that the **Extended standby** checkbox is marked, then tap **Apps active in standby > Add applications**.
- 4 Scroll left or right to add or remove applications and services as desired.
- 5 When you're finished, tap **Done**.

To restrict the hardware performance

- 1 From your Home screen, tap ☰.
 - 2 Find and tap **Settings > Battery**, then tap **STAMINA mode**.
 - 3 Mark the **Extended usage** checkbox, then tap **Turn on**, if prompted.
- ! If you notice a sharp reduction in performance when this function is activated, unmark the Extended usage checkbox to deactivate it.

Improving battery time using Low battery mode

Use the **Low battery mode** feature to automatically start saving power when the battery reaches a certain charge level. You can set and readjust this charge level as desired. You can also decide which functions to keep active, for example, mobile data traffic, Wi-Fi® or auto-sync.

- ! If you are using a device with multiple users, only the owner, that is, the primary user, can adjust the settings for Low battery mode as well as activate or deactivate the feature. Changes made by the owner affect all other users.

To activate Low battery mode

- 1 From your Home screen, tap ☰.
- 2 Find and tap **Settings > Battery**.
- 3 Drag the slider beside **Low battery mode** to the right.
- 4 If prompted, tap **Turn on**. 📶 appears in the status bar when the battery reaches the charge level that you set.

To change the settings for Low battery mode

- 1 From your Home screen, tap ☰.
- 2 Find and tap **Settings > Battery**.
- 3 Make sure that **Low battery mode** is activated, then tap **Low battery mode**.
- 4 Change the settings, for example, readjust the battery level.

Improving battery time by queuing background data

You can improve battery performance by setting your device to send background data at pre-defined intervals when you're not using it, that is, when the screen is not active. If you are using a device with multiple users, you may need to log in as the owner, that is, the primary user, to allow or disallow the queuing of background data. Changes made by the owner affect all other users.

To allow the queuing of background data

- 1 From your Home screen, tap ☰.
- 2 Find and tap **Settings > Battery**.
- 3 Mark the checkbox beside **Queue background data**.

Memory and storage

Your device has different types of memory and storage possibilities for photos, apps, and other files:

- The **internal storage** is about **32 GB** and is used to store downloaded or transferred content along with personal settings and data. Examples are alarm, volume and language settings, emails, bookmarks, contacts, calendar events, photos, videos, and music.
- You can use a removable **memory card** of up to **32 GB** to get more storage space. Most applications can read data from a memory card but only certain apps can save files to this type of memory. You can, for example, set the camera application to save photos directly to the memory card.
- The **dynamic memory (RAM)**

is about **2 GB** and cannot be used for storage. RAM is used to handle running applications and the operating system.

! You may have to purchase a memory card separately.

Read more about the use of memory in Android devices by downloading the white paper for your device at www.sonymobile.com/support.

Improving memory performance

The memory in your device tends to fill up as a result of normal usage. If the device starts to slow down, or applications suddenly shut down, you should consider the following:

- Always have more than **100 MB** of free internal storage and more than **100 MB** of free RAM.
- Close down running applications that you are not using.
- Clear the memory cache for all applications.
- Uninstall downloaded applications that you don't use.
- Transfer photos, videos, and music from the internal memory to the memory card.
- If your device can't read content on the memory card, you may need to format it.

To view the memory status

- 1 From your Home screen, tap ☰.
- 2 Find and tap **Settings > Storage**.

To view the amount of free and used RAM

- 1 From your Home screen, tap ☰.
- 2 Find and tap **Settings > Application manager > Running**.

To clear the memory cache for all applications

- 1 From your Home screen, tap ☰.
- 2 Find and tap **Settings > Storage**.
- 3 Tap **Cached data > OK**.

! When you clear the memory cache, you don't lose any important information or settings.

To transfer media files to the memory card

- 1 Make sure you have a memory card inserted in your device.
- 2 From your Home screen, tap ☰.
- 3 Find and tap **Settings > Storage > Transfer data to SD card**.
- 4 Mark the file types you want to transfer to the memory card.
- 5 Tap **Transfer**.

To stop applications and services from running

- 1 From your Home screen, tap ☰.
- 2 Find and tap **Settings > Application manager > Running**.
- 3 Select an application or service, then tap **Stop**.

To format the memory card

- 1 From your Home screen, tap ☰.
- 2 Find and tap **Settings > Storage > Erase SD card**.
- 3 To confirm, tap **Erase SD card > Erase everything**

! All content on the memory card gets erased when you format it. Be sure to make backups of all data that you want to save before formatting the memory card. To back up your content, you can copy it to a computer. For more information, see *Managing files using a computer* on the 90 page.

Managing files using a computer

Use a USB cable connection between a Windows® computer and your device to transfer and manage your files. Once the two devices are connected, you can drag and

drop content between your device and the computer, or between your device's internal storage and SD card, using the computer's file explorer.

This is where files are stored on your device:

- Photos and videos taken by the camera: Internal storage or SD card\DCIM.
- Downloaded files from the Internet: Internal storage or SD card\Downloads.
- Files received via Bluetooth®: Internal storage or SD card\bluetooth.
- Files received via Android Beam (NFC): Internal storage\beam.
- Screenshots taken on your device: Internal storage\DCIM\Pictures\Screenshots.

Transferring files using Media transfer mode via Wi-Fi®

You can transfer files between your device and other MTP compatible devices, such as a computer, using a Wi-Fi® connection. Before connecting, you first need to pair the two devices.



In order to use this feature, you need a Wi-Fi® enabled device that supports Media transfer, for example, a computer running Microsoft® Windows Vista® or Windows® 7.

To prepare to use your device wirelessly with a computer

- 1 Make sure Media transfer mode is enabled on your device. It is normally enabled by default.
- 2 Connect your device to the computer using a USB cable.
- 3 **Computer:** Once the name of your device appears on the screen, click *Configure device for network access* and follow the instructions to pair the computer and your device.
- 4 When you are done pairing, disconnect the USB cable from both devices.

To connect wirelessly to a paired device

- 1 Make sure Media transfer mode is enabled on your device. It is normally enabled by default.
- 2 Make sure the Wi-Fi® function is turned on.
- 3 From your Home screen, tap ::::.
- 4 Find and tap **Settings > Xperia™ Connectivity > USB Connectivity**.
- 5 Under **Wireless Media Transfer**, select the paired device you want to connect to.
- 6 Tap **Connect**.

To disconnect from a paired device

- 1 From your Home screen, tap ::::.
- 2 Find and tap **Settings > Xperia™ Connectivity > USB Connectivity**.
- 3 Under **Wireless Media Transfer**, select the paired device that you want to disconnect.
- 4 Tap **Disconnect**.

To remove a pairing with another device

- 1 From your Home screen, tap ::::.
- 2 Find and tap **Settings > Xperia™ Connectivity > USB Connectivity**.
- 3 Select the paired device that you want to remove.
- 4 Tap **Unpair**.

Restarting and resetting

You can force your device to shut down in situations where it stops responding or won't restart normally. No settings or personal data get deleted. You can also reset your device to its original factory settings, with or without deleting all of your personal data. This action is sometimes necessary if your device stops functioning properly.

- ! Your device may fail to restart if the battery level is low. Connect your device to a charger and try restarting again.

To force the device to shut down

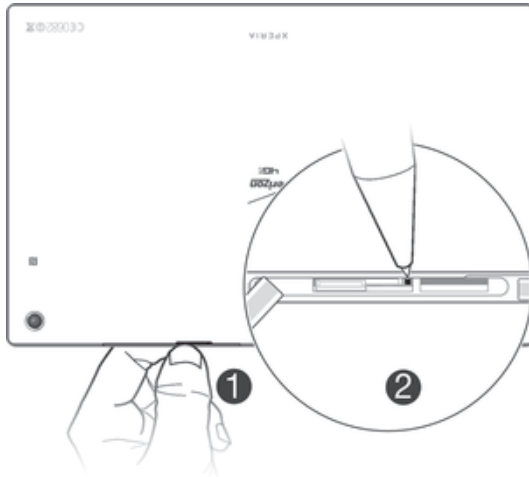

- 1 Remove the cover for the memory card and the nano SIM card.
- 2 Using the tip of a pen or a similar object, press and hold down the OFF button until the device shuts down.

! Do not use overly sharp objects that could damage the OFF button.

To perform a factory data reset

! To avoid permanent damage to your device, do not restart your device while a reset procedure is underway.

- 1 Before you start, make sure to back up any important data that is saved on the internal memory of your device to a memory card or other non-internal memory.
- 2 From your Home screen, tap ⋮ .
- 3 Find and tap **Settings** > **Backup & reset** > **Factory data reset**.
- 4 Tap **Reset tablet**.
- 5 If required, draw your screen unlock pattern, or enter your screen unlock password or PIN to continue.
- 6 To confirm, tap **Erase everything**.

Using your device in wet and dusty conditions

! To ensure the water resistance of your device, all covers, including the covers for the micro USB port, the SIM card slot and the memory card slot, must be firmly closed.

Your smart device is waterproof and dust resistant in compliance with the Ingress Protection (IP) ratings IP55 and IP58, as explained in the table below. To view more specific IP information about your device, go to www.sonymobile.com/global-en/legal/testresults/ and click on the relevant device name.

These specific IP ratings mean that your device is dust resistant and is protected against low pressure water stream as well as against the effects of immersion for 30 minutes in fresh (non-saline) water up to 1.5 meters deep.

You can use your device:

- in dusty environments, for example, on a windy beach.
- when your fingers are wet.
- in some extreme weather conditions, for example, when it's snowing or raining.
- in fresh (non-saline) water depths of 1.5 meters or less, for example, in a fresh water lake or river.
- in a chlorinated swimming pool.

Even if your device is resistant to dust and water, you should avoid exposing it unnecessarily to environments with excessive dust, sand and mud or to moist environments with extreme high or low temperatures. The waterproof ability of the micro USB port, the SIM card slot, the memory card slot and the headset jack cannot be guaranteed in all environments or conditions.

Never immerse your device in salt water or let the micro USB port or headset jack come in contact with salt water. For example, if you're at the beach, remember to keep your device away from the sea water. Also, never expose the device to any liquid chemicals. For example, if you're washing dishes by hand using liquid detergent, avoid bringing your device in contact with the detergent. After exposure to non-fresh water, rinse your device using fresh water.

Normal wear and tear along with damage to your device can reduce its ability to resist dust or moisture. After using the device in water, dry off the areas around all covers, including the covers for the micro USB port, the SIM card slot and the memory card slot.

If the speaker or microphone get wet, their function may be impacted until the water has completely dried. Please note that the drying time can be up to three hours depending on the environment. During this time, you can, however, use other features in the device that do not utilize the speaker or microphone. All compatible accessories, including batteries, chargers, handsfree devices and micro USB cables, are not waterproof and dust resistant on their own.

Your warranty does not cover damage or defects caused by abuse or improper use of your device (including use in environments where the relevant IP rating limitations are exceeded). If you have any further questions about the use of your products, refer to our Customer support service for help.

IP (Ingress Protection) rating

Your device has an IP rating, which means it has undergone certified tests to measure its resistance levels to both dust and water. The first digit in the two-digit IP rating indicates the level of protection against solid objects, including dust. The second digit indicates how resistant the device is to water.

Resistance to solid objects and dust	Resistance to water
IP0X: No special protection	IPX0: No special protection
IP1X: Protected against solid objects > 50 mm in diameter	IPX1: Protected against dripping water
IP2X: Protected against solid objects > 12.5 mm in diameter	IPX2: Protected against dripping water when tilted up to 15 degrees from normal position
IP3X: Protected against solid objects > 2.5 mm in diameter	IPX3: Protected against spraying water
IP4X: Protected against solid objects > 1 mm in diameter	IPX4: Protected against splashing water
IP5X: Protected against dust; limited ingress (no harmful deposits)	IPX5: Protected against water jet spray for at least 3 minutes
IP6X: Dust-tight	IPX6: Protected against heavy jet spray for at least 3 minutes
	IPX7: Protected against the effects of immersion in up to 1 meter of water for 30 minutes
	IPX8: Protected against the effects of continued immersion in water at depths greater than 1 meter. The exact conditions are specified for each device by the manufacturer.

! For more information, go to www.sonymobile.com/testresults.

Recycling your device

Got an old device lying around the house? Why not recycle it? By doing so, you will help us reuse its materials and components, and you'll protect the environment, too! Find out more about the recycling options in your region at www.sonymobile.com/recycle.

Limitations to services and features

Some of the services and features described in this User guide are not supported in all countries/regions or by all networks and/or service providers in all areas. Without limitation, this applies to the GSM International Emergency Number, 112. Please contact your network operator or service provider to determine availability of any specific service or feature and whether additional access or usage fees apply.

Use of certain features and applications described in this guide may require access to the Internet. You may incur data connection charges when you connect to the Internet from your device. Contact your wireless service provider for more information.

Legal information

SonySGP561

This User guide is published by Sony Mobile Communications AB or its local affiliated company, without any warranty. Improvements and changes to this User guide necessitated by typographical errors, inaccuracies of current information, or improvements to programs and/or equipment, may be made by Sony Mobile Communications AB at any time and without notice. Such changes will, however, be incorporated into new editions of this User guide. All illustrations are for illustration purposes only and may not accurately depict the actual device. All product and company names mentioned herein are the trademarks or registered trademarks of their respective owners. All other trademarks are property of their respective owners. Any rights not expressly granted herein are reserved. Visit www.sonymobile.com/us/legal/ for more information.

This User guide may reference services or applications provided by third parties. Use of such programming or services may require separate registration with the third party provider and may be subject to additional terms of use. For applications accessed on or through a third-party website, please review such websites' terms of use and applicable privacy policy in advance. Sony does not warrant or guarantee the availability or performance of any third-party websites or offered services.

Your mobile device has the capability to download, store, and forward additional content, for example, ringtones. The use of such content may be restricted or prohibited by rights of third parties, including but not limited to restriction under applicable copyright laws. You, and not Sony, are entirely responsible for additional content that you download to or forward from your mobile device. Prior to your use of any additional content, please verify that your intended use is properly licensed or is otherwise authorized. Sony does not guarantee the accuracy, integrity, or quality of any additional content or any other third-party content. Under no circumstances will Sony be liable in any way for your improper use of additional content or other third-party content.

Visit www.sonymobile.com/ for more information.

This product is protected by certain intellectual property rights of Microsoft. Use or distribution of such technology outside of this product is prohibited without a license from Microsoft.

Content owners use Windows Media digital rights management technology (WMDRM) to protect their intellectual property, including copyrights. This device uses WMDRM software to access WMDRM-protected content. If the WMDRM software fails to protect the content, content owners may ask Microsoft to revoke the software's ability to use WMDRM to play or copy protected content. Revocation does not affect unprotected content. When you download licenses for protected content, you agree that Microsoft may include a revocation list with the licenses. Content owners may require you to upgrade WMDRM to access their content. If you decline an upgrade, you will not be able to access content that requires the upgrade.

This product is licensed under the MPEG-4 visual and AVC patent portfolio licenses for the personal and non-commercial use of a consumer for (i) encoding video in compliance with the MPEG-4 visual standard ("MPEG-4 video") or the AVC standard ("AVC video") and/or (ii) decoding MPEG-4 or AVC video that was encoded by a consumer engaged in a personal and non-commercial activity and/or was obtained from a video provider licensed by MPEG LA to provide MPEG-4 and/or AVC video. No license is granted or shall be implied for any other use. Additional information including that relating to promotional, internal and commercial uses and licensing may be obtained from MPEG LA, L.L.C. See <http://www.mpegla.com>. MPEG Layer-3 audio decoding technology licensed from Fraunhofer IIS and Thomson.

SONY MOBILE WILL NOT BE LIABLE FOR ANY LOSS, ERASE AND/OR DATA-OVERWRITING OF PERSONAL DATA OR FILES STORED ON YOUR DEVICE (INCLUDING BUT NOT LIMITED TO CONTACTS, MUSIC TRACKS AND PICTURES) ARISING OUT OF ANY UPDATE OF YOUR DEVICE BY ANY OF THE METHODS DESCRIBED IN THIS USER GUIDE OR DOCUMENTATION. IN NO EVENT SHALL SONY MOBILE'S OR ITS SUPPLIERS' TOTAL LIABILITY TO YOU FOR ANY AND ALL DAMAGES, LOSSES AND CAUSES OF ACTION (WHETHER IN CONTRACT OR TORT, INCLUDING, BUT NOT LIMITED TO NEGLIGENCE OR OTHERWISE) EXCEED THE AMOUNT ACTUALLY PAID BY YOU FOR YOUR DEVICE.

©Sony Mobile Communications AB, 2014.

All rights reserved